

t1000-800 SERIES

ELASTOMER CLAW COUPLING

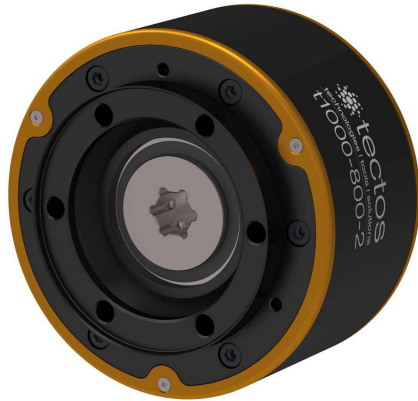

DESCRIPTION

The t1000-800 has been especially developed for use in motor sport, two-wheel applications, and special applications, for example tests with dual mass flywheels or original vehicle clutches. This coupling is characterized by its relatively low weight, very robust design, high damping capability and easy maintenance.

The development aim of this coupling (to transfer very high alternating torques at low stiffness) was achieved in various different designs.

The design principle of the coupling allows the torsional stiffness to be adjusted for different requirements by using elastomers of varying hardness.

NAMING

The product is named according to the following convention:

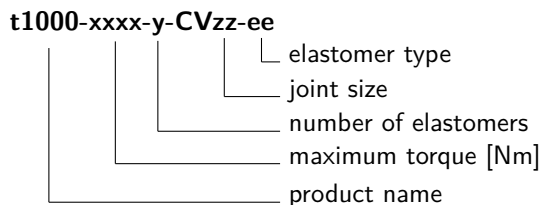

Example: *t1000-800-1-CV05-SN*

OPERATING RANGE

Torque: up to 800 Nm
Speed: up to 10000 rpm

BENEFITS

- for high dynamic loads
- fast exchange of the elastomer
- compact and modular design
- no elastomer failure when overloaded
- no shaft damage when elastomer fails
- high damping and long lifetime
- stiffness adjustment by elastomer placement

FUNCTION

The design provides a strongly non-linear coupling characteristic. The special design allows problem-free adaptation to new applications and a short downtime when exchanging the elastomers.



Exclusive Representative in Japan

 TOKYO PLANT Co., Ltd.
東京プラント株式会社

515-5 Miyazawa-cho, Akishima city, Tokyo, Japan 196-0024
TEL: +81-42-546-6500 FAX: +81-42-546-6600
Email: sales@tokyo-plant.co.jp

t1000-800 SERIES

ELASTOMER CLAW COUPLING

t1000-800		
Nominal torque ¹ T_{KN}	[Nm]	800
Maximum torque T_{Kmax}	[Nm]	1500
Maximum alternating torque T_{KW}	[Nm]	700
Maximum speed	[rpm]	10000
Relative damping Ψ	[-]	0.1 - 0.35
Operating temperature for elastomer made of natural rubber ²	[°C]	80
Number of toothed ring teeth for speed measurement ³	[-]	64

Coupling	Joint	m	x_s	α_{max}	J_1	J_2	c_{Tdyn}
		[kg]	[mm]	[°]	[kgm ²]	[kgm ²]	[Nm/rad]
t1000-800-1	CV05	2.51	29.9	7.5	2.26E-03	3.54E-03	2000 - 12000
	CV15	2.50	28.9		2.32E-03	3.52E-03	
t1000-800-2	CV05	3.89	46.6	15.0	3.70E-03	5.28E-03	1000 - 6000
	CV15	3.87	45.6		3.80E-03	5.26E-03	
t1000-800-3	CV05	5.26	63.0	22.5	5.06E-03	6.97E-03	700 - 3000
	CV15	5.25	62.0		5.12E-03	6.96E-03	

m - Mass

x_s - Center of gravity flange-side

c_{Tdyn} - Torsional stiffness

α_{max} - Maximum torsional angle

J_1 - Inertia flange-side

J_2 - Inertia shaft-side

Elastomer type	Material	Shore hardness
HN	Natural rubber	45 - 50° Shore A
EN		50 - 55° Shore A
WN		53 - 58° Shore A
NN		63 - 68° Shore A
SN (Standard)		73 - 78° Shore A
UN		83 - 88° Shore A

¹The nominal torque must be equal to or greater than the maximum combustion engine torque

²Silicone elastomers for higher temperatures are available on request

³Toothed rings for rotational speed measurement available as an option

t1000-800 SERIES

ELASTOMER CLAW COUPLING

Elastomer type	t1000-800-1			t1000-800-2			t1000-800-3		
	cp ₁	cp ₃	Ψ	cp ₁	cp ₃	Ψ	cp ₁	cp ₃	Ψ
	[Nm/rad]	[Nm/rad ³]	[-]	[Nm/rad]	[Nm/rad ³]	[-]	[Nm/rad]	[Nm/rad ³]	[-]
HN	1622	217894	0.10	811	27237	0.10	541	8070	0.10
EN	2043	259170	0.10	1022	32396	0.10	681	9599	0.10
WN	2696	270138	0.15	1348	33767	0.15	899	10005	0.15
NN	3144	449459	0.25	1572	56182	0.25	1048	16647	0.25
SN	4617	581122	0.30	2309	72640	0.30	1539	21523	0.30
UN	6484	1136191	0.35	3242	142024	0.35	2161	42081	0.35

cp₁ - Linear stiffness coefficient

cp₃ - Non-linear stiffness coefficient

Ψ - Relative damping

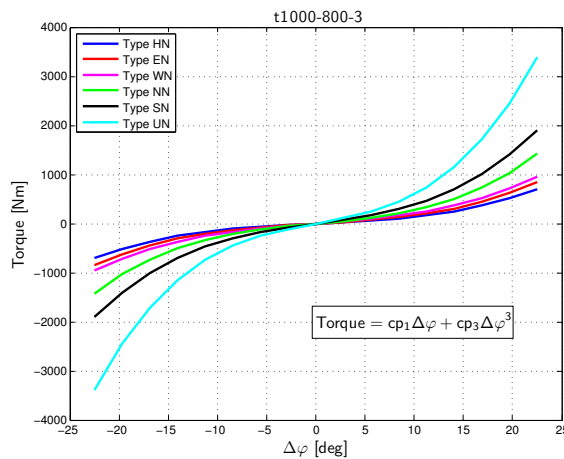
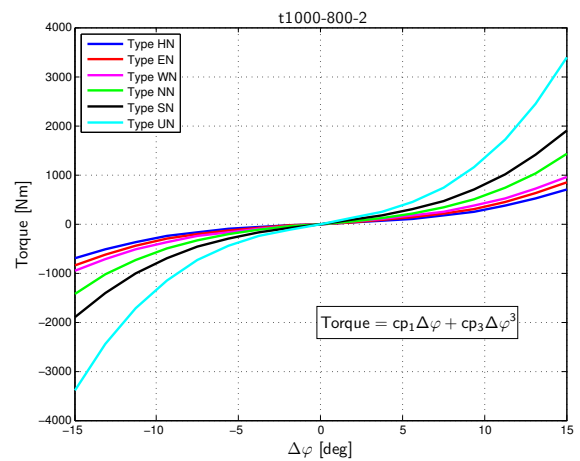
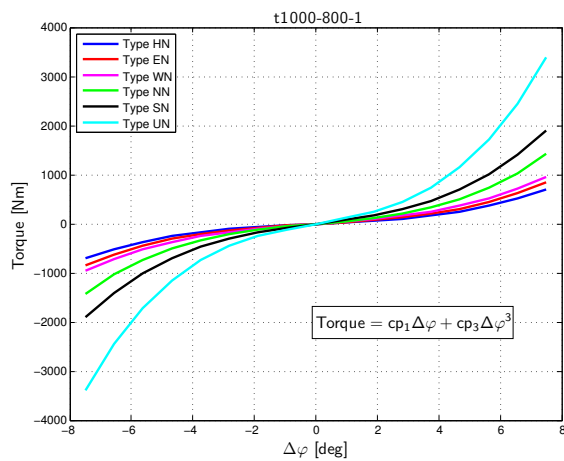

t1000-800 SERIES

ELASTOMER CLAW COUPLING

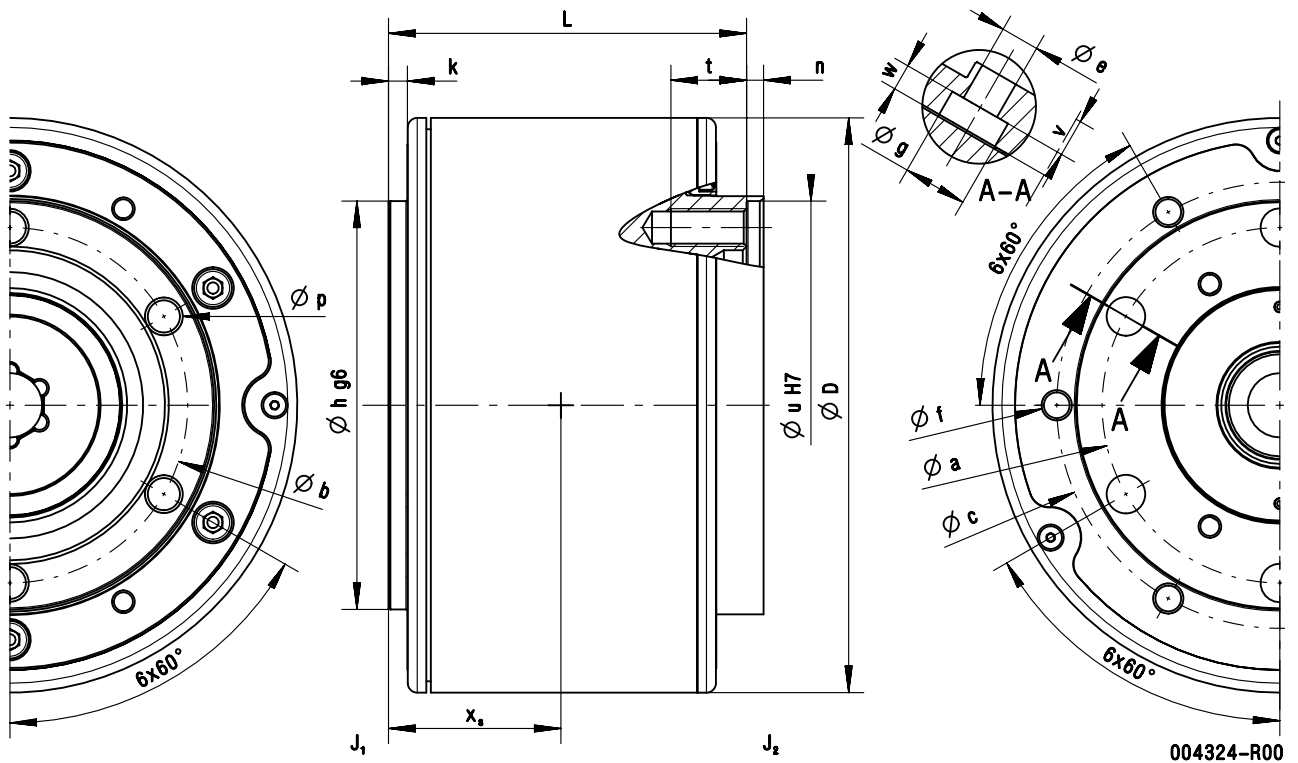

Coupling	Joint	D	L	a	b	c	e	f	g	h (g6)	k	n	p	t	u (H7)	v	w
		[mm]	[mm]	[mm]	[mm]	[mm]	[mm]	[-]	[mm]	[mm]	[mm]	[mm]	[-]	[mm]	[mm]	[mm]	[mm]
t1000-800-1	CV05	152	62.6	74	74	118	8.2	M8	15	86	5	10.5	M8	16	86	10	7
	CV15	152	62.6	94	94	118	10.2	M8	17	108	5	4.5	M10	20	108	10	7
t1000-800-2	CV05	152	94.7	74	74	118	8.2	M8	15	86	5	10.5	M8	16	86	10	7
	CV15	152	94.7	94	94	118	10.2	M8	17	108	5	4.5	M10	20	108	10	7
t1000-800-3	CV05	152	126.8	74	74	118	8.2	M8	15	86	5	10.5	M8	16	86	10	7
	CV15	152	126.8	94	94	118	10.2	M8	17	108	5	4.5	M10	20	108	10	7

Other dimensions available on request

2018-01-18 <b3e461451e7b3b2f00b75258faab9ceccf0d6ece> DS EN 18