

Tanaka's Hydraulic Dynamometer Product Catalog

■ General

Tanaka's Hydraulic Dynamometer is a world representative hydraulic dynamometer. It has been introduced in many references, such as Automotive Engineering Handbook. It has great durability, high accuracy and low inertia. It has been introduced to many customers both domestically and internationally.

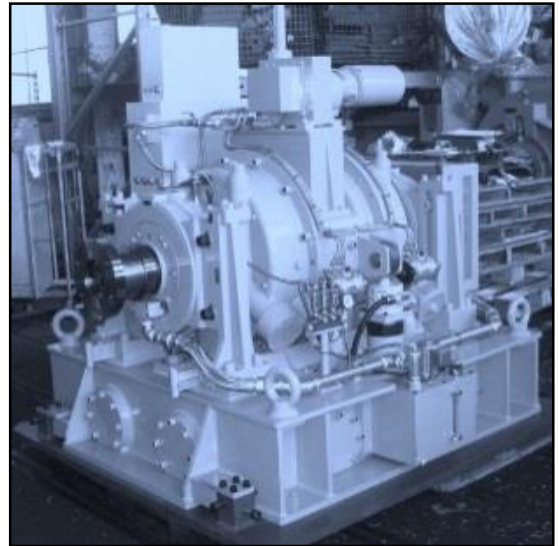

■ Technological Capability

Award record: Medal with Purple Ribbon (1972), Tokyo Governor's Prize (1969)

Patents: Japan, UK, USA

■ Past Performance

History: 50 year and counting (the 1st model in 1964)

* the first-made machine was for Komatsu and Hino Motors.

Cumulative Number of machines: 2000 and counting (No. 1 market share in Japan)

Destination: Japan and more than 40 countries

Major users: OEM (off-road, automobile), component supplier, gas company, heavy duty engine maintenance shop, JGSDF

■ Major customers

Yanmar, IHI, Niigata Power Systems, Komatsu, IPA, Daihatsu Diesel MFG, Mitsubishi Heavy Industries, Hitachi, Ebara, Kubota, Shinko Engineerings, Kanzaki Kogyokoki MFG, Tokiwa MFG, Komatsu Construction Equipment Sales and Service Japan, Tominaga, Mitsubishi Heavy Industries Engine Systems, Mitsubishi Fuso Truck and Bus, Mitsui Zosen Machinery & Service, Okinawa Kikai Seibi, Otsuka Diesel, Osaka Gas, Akasaka Diesels, Kyowa Industrial, Toyo Nainenki Kogyosha, Daito Kosakusho, Maruma, Isuzu Marine Engine, Tokai Rolling Stock & Machinery, Nissan Motor, Yamaha Motor, NGK Spark Plug, Mitsuboshi Belting, Ishibashi Manufacturing, Nakata Engine, Ogura Clutch, universities, colleges of technologies, research institutes, JGSDF, JMSDF service school, Naval Air Facility Atsugi and etc.

(Total of 500 companies)

■ Characteristics

High performance	<ul style="list-style-type: none"> Load can be adjusted in a short time. The structure that erosion due to cavitation unlikely occur. Manual push buttons, automatic speed and torque control. Speed and torque can be controlled by programmed operation from automation system. Alarm signal generates when overspeed and oil failure. Relay contact can be set.
Compact and lightweight	<ul style="list-style-type: none"> Small installation space. 30% lighter than conventional model.
Easy operation	<ul style="list-style-type: none"> Long time continuous operation due to oil lubrication. Speed and torque employs digital indicator as standard. Outputs analog voltages of speed and torque. Connector is employed to prevent cable disconnection.
Options (Chargeable)	<ul style="list-style-type: none"> Marine property control Rapid load variation operation test by intermissive water supply/drainage valve Main shaft lock device and disc brake device Center height variation as requested Location of anchor bolts for a stand can be manufactured according to customer's request.

■ Principle and Structure

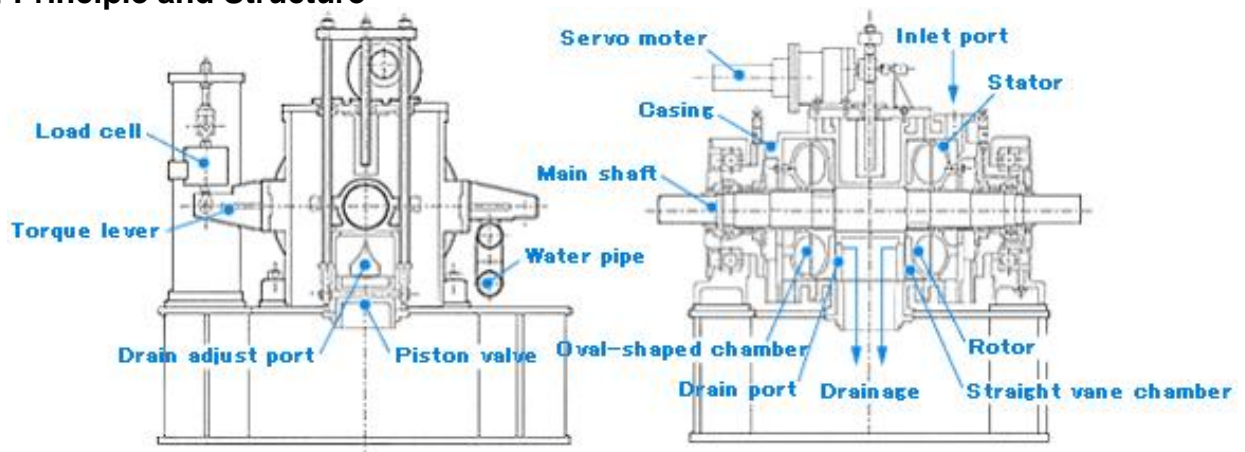

- When the main shaft rotates, water applies braking force to rotor and rotating force to stator (applied to a load cell) by friction in the oval-shaped impeller chamber.
- Water flow in the straight vane chamber at the back of the rotor is adjusted in order to increase/decrease absorbed power. The water level of the outlet port in radial direction by piston valve is varied to adjust the pressure generated by the straight vane.

■ Applications

○ Targets

- Marine engine
- Agricultural machine engine
- Construction vehicle engine
- Generator
- Turbine
- Pump
- Truck engine
- Motorcycle engine
- Gear box

○ Tests

- Durability performance test
- Partial load performance test
- Full-open performance test
- Marine cube test
- Component evaluation test
- other performance tests (steady state)...

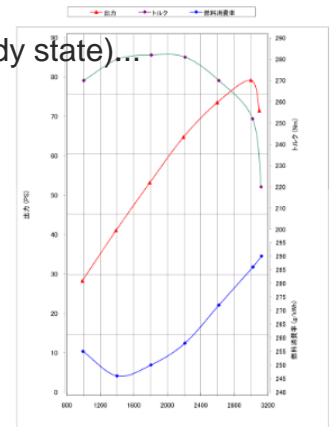
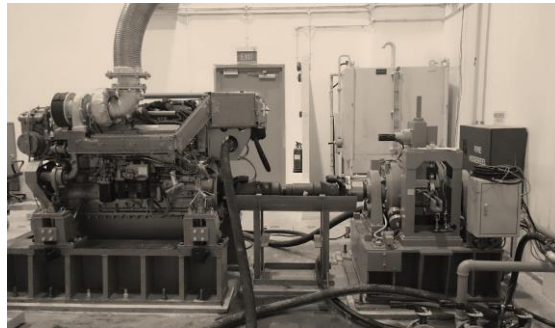

■ System Configuration

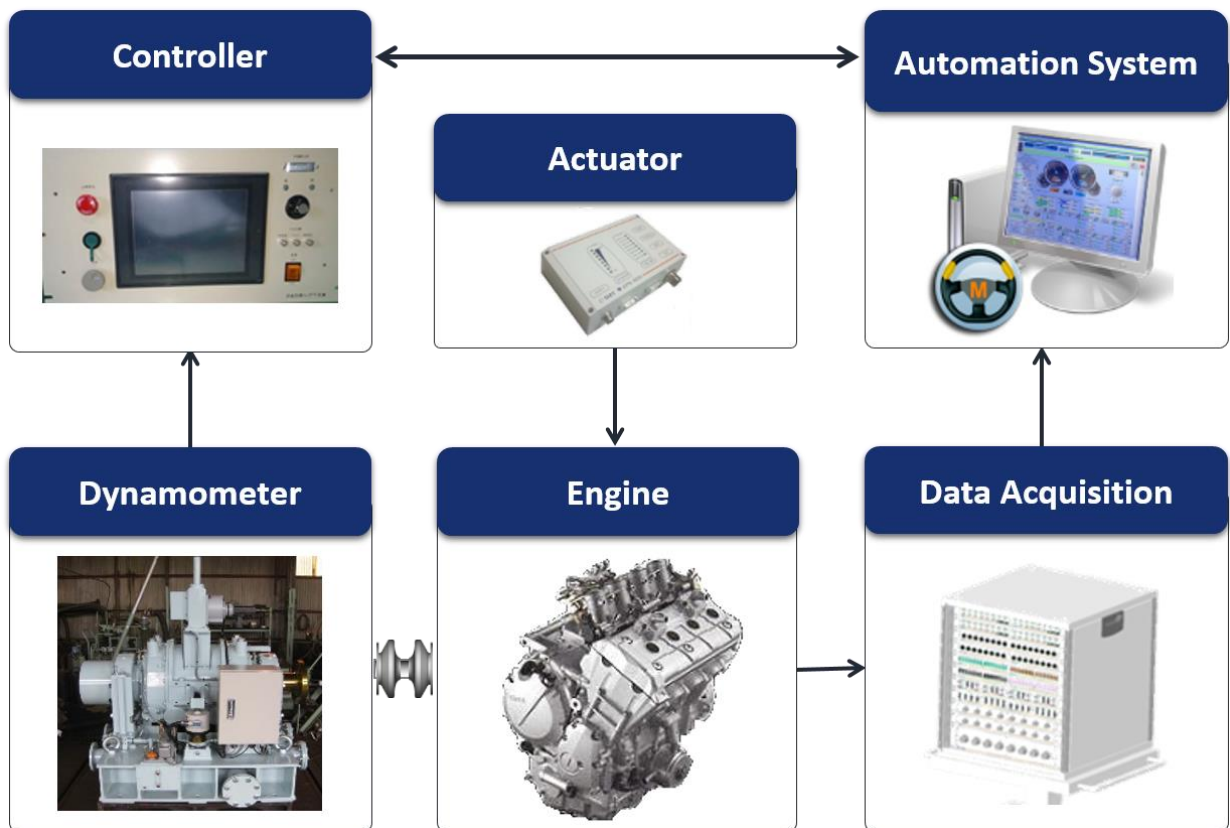

We can offer the most suitable testbed engineering to customers. Please contact us for further details about automation system, data acquisition sensors, testbed layout and shaft couplings. We can offer the suitable proposal for your budget and request.

■ Product range

OP-A type (irreversible type)

Best product range for the test of middle to large diesel engines

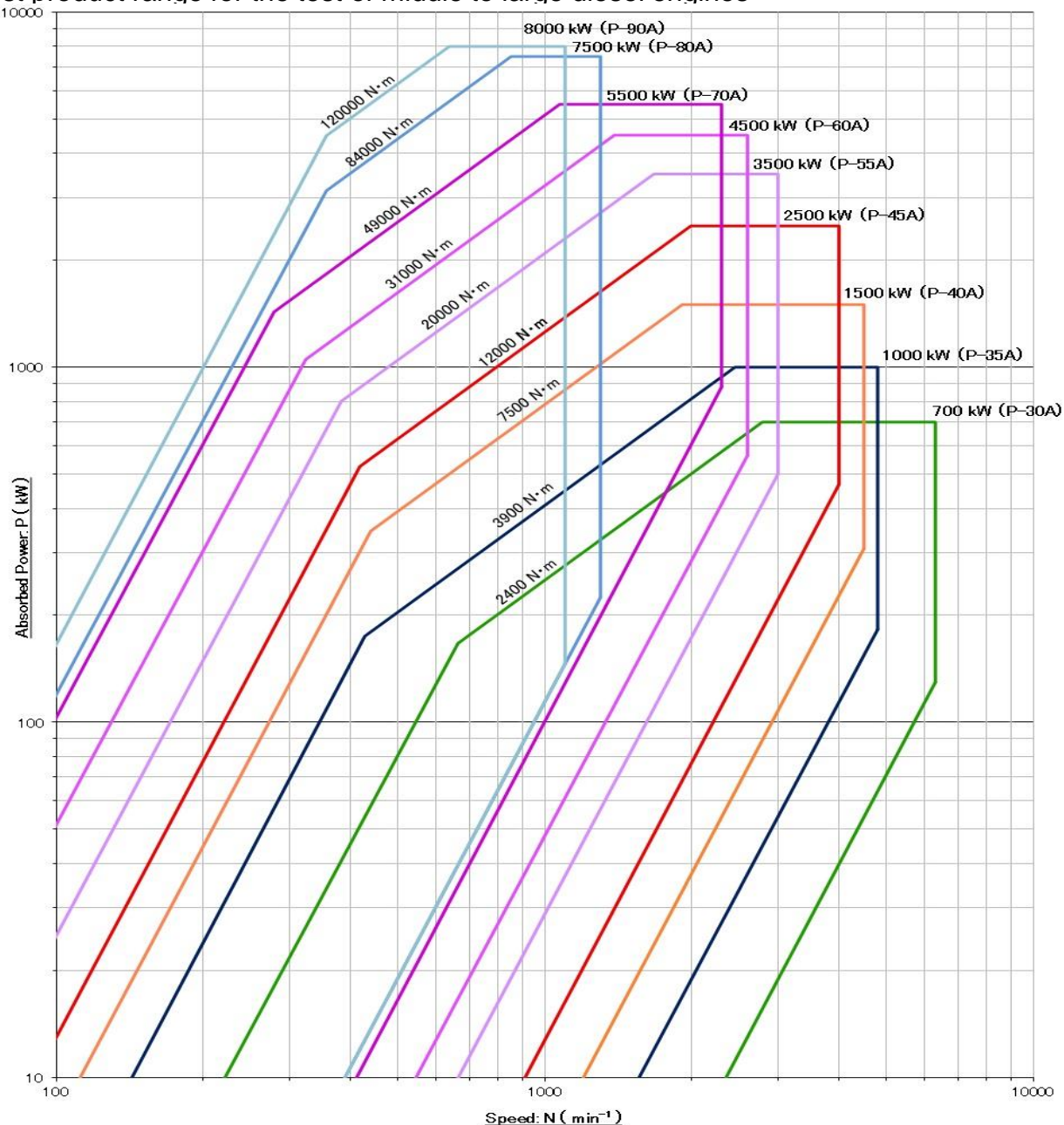

Model	Max. braking power kW	Max. braking torque Nm	Max. speed min ⁻¹	Constant torque range min ⁻¹	Inertia kg.m ²	Cooling water L/min
P-30A	700	2,400	5,300	656~2,785	0.437	400
P-35A	1,000	3,900	4,800	429~2,448	0.975	570
P-40A	1,500	7,500	4,500	438~1,909	1.88	860
P-45A	2,500	12,000	4,000	415~1,989	2.85	1,430
P-55A	3,500	20,000	3,000	380~1,671	8.165	2,000
P-60A	4,500	31,000	2,600	320~1,386	15.275	2,580
P-70A	5,500	49,000	2,300	319~1,071	31.225	3,150
P-80A	7,500	84,000	1,300	352~852	41.483	4,300
P-90A	8,000	120,000	1,200	355~636	78	4,580

* Water flow: theoretical water flow when inlet water temp is 35° C and outlet water temp is 60° C.

* Specification is subject to change due to product modification.

■ Product range

OP-A type: Dry weight and dimension

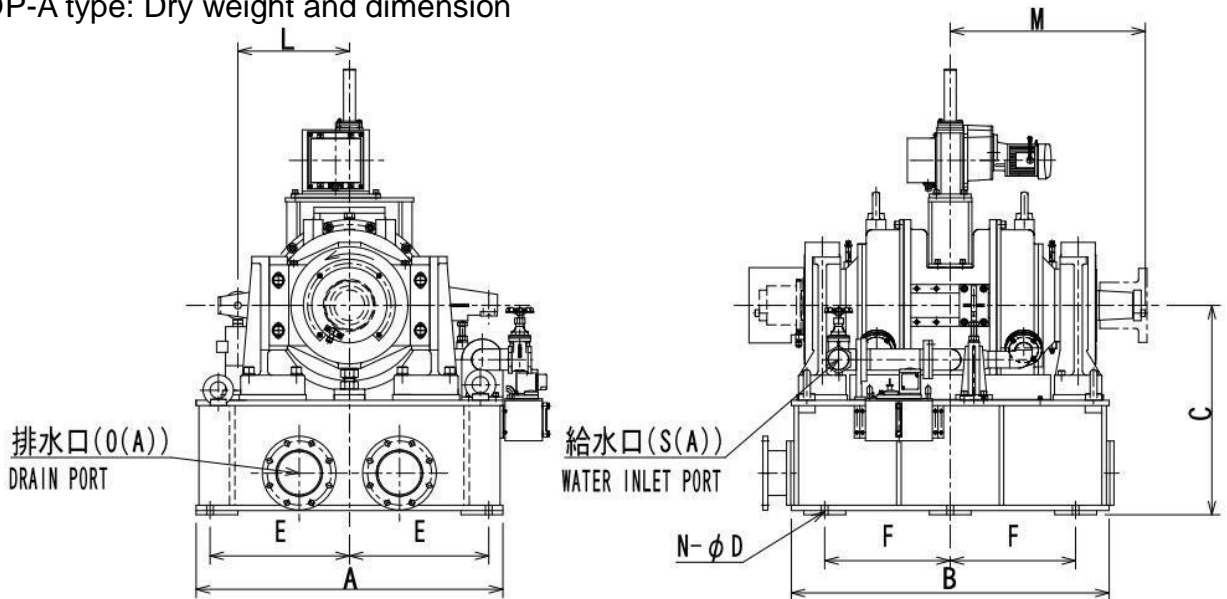

Model	Mass kg	Dimension									
		A	B	C	E	F	N-φD	L	M	S(A)	O(A)
P-30A	1,100	950	820	600	420	320	4-24	358.1	500	50	125
P-35A	1,550	1,100	940	650	500	350	4-24	400	600	50	150
P-40A	1,600	1,100	970	650	500	350	4-24	375	635	50	150
P-45A	2,100	1,100	1,060	750	500	425	6-24	430	680	65	150
P-55A	3,500	1,400	1,200	750	650	500	6-24	500	835	80	150
P-60A	4,700	1,700	1,300	950	815	600	6-24	680	970	80	200
P-70A	7,500	1,980	1,750	1,100				800	1,085	100	200
P-80A	11,000	2,000	2,200	1,200				800	1,230	125	200
P-90A	17,000	2,000	2,550	1,200				800	1,345	150	300

* Mass is determined by a stand and specification.

* Specification is subject to change due to product modification.

Standard Accessories	<ul style="list-style-type: none"> • Dyno main body, stand and load control remote controller • Bearing temp sensor • Inlet cooling water temp sensor • Outlet water temp sensor
Option (Chargeable)	<ul style="list-style-type: none"> • Dyno controller (manual or automatic control system) • Coupling flange on the dyno side • Calibration inspection tool (tool for dyno calibration) • Bearing height adjusting device (for centering work) • Centering bedplate (adjusting in X/Y/Z direction for centering work) • Rapid load variation device (the best option to the rapid load variation test) • Flowmeter for cooling water • Inlet water valve • Outlet water valve

■ Product range

○PRS-A type (reversible type)

Best product range for the test of middle to large diesel engines

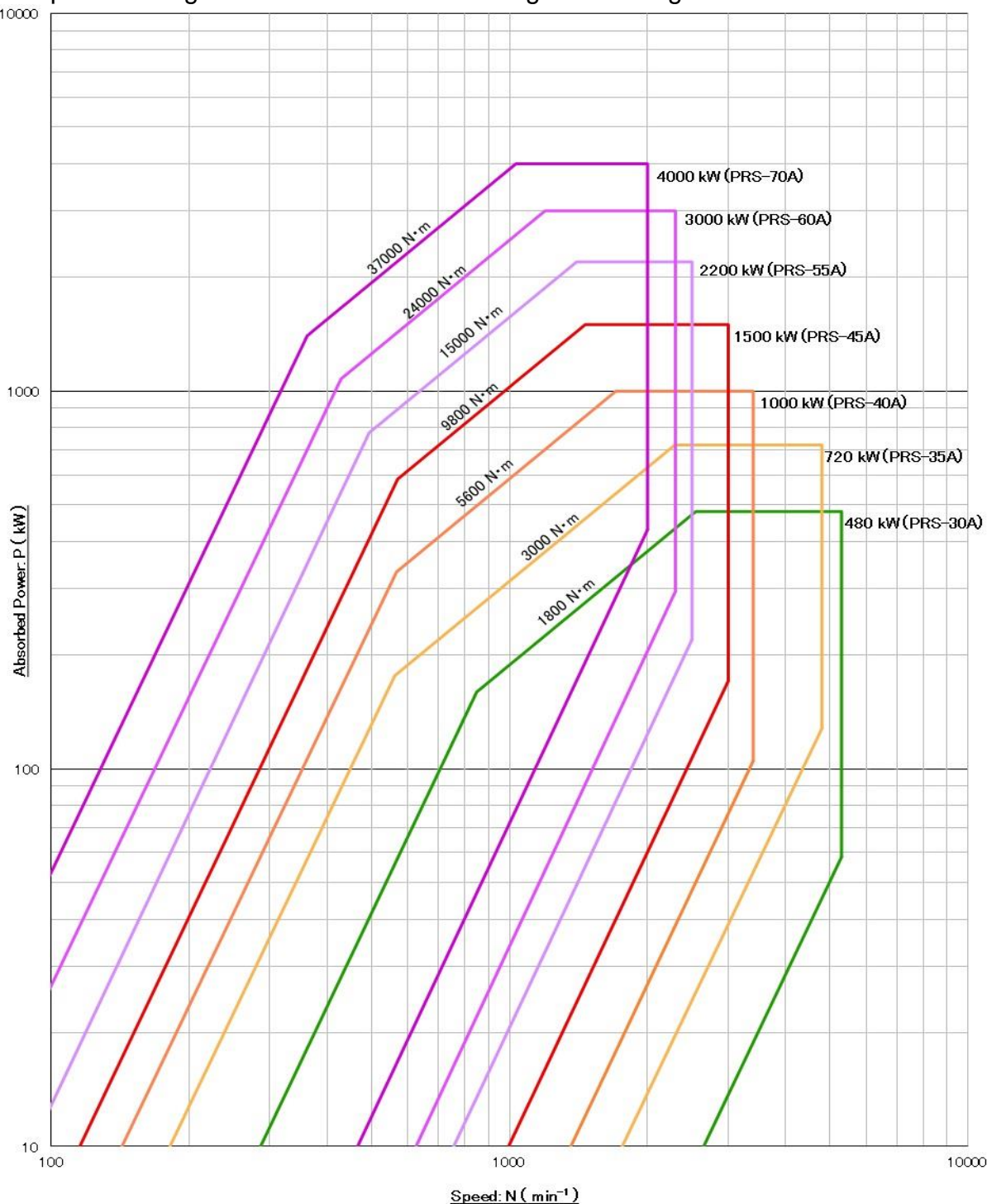

Model	Max. braking power kW	Max. braking torque Nm	Max. speed min ⁻¹	Constant torque range min ⁻¹	Inertia kg.m ²	Cooling water L/min
PRS-30A	480	1,800	5,300	834~2,546	0.437	275
PRS-35A	720	3,000	4,800	552~2,291	0.975	420
PRS-40A	1,000	5,600	3,400	553~1,705	1.88	570
PRS-45A	1,500	9,800	3,000	557~1,461	2.85	860
PRS-55A	2,200	15,000	2,500	487~1,400	8.165	1,260
PRS-60A	3,000	24,000	2,300	417~1,193	15.275	1,720
PRS-70A	4,000	37,000	2,000	354~1,032	31.225	2,290

■ Product range

OPRS-A type: Dry weight and dimension

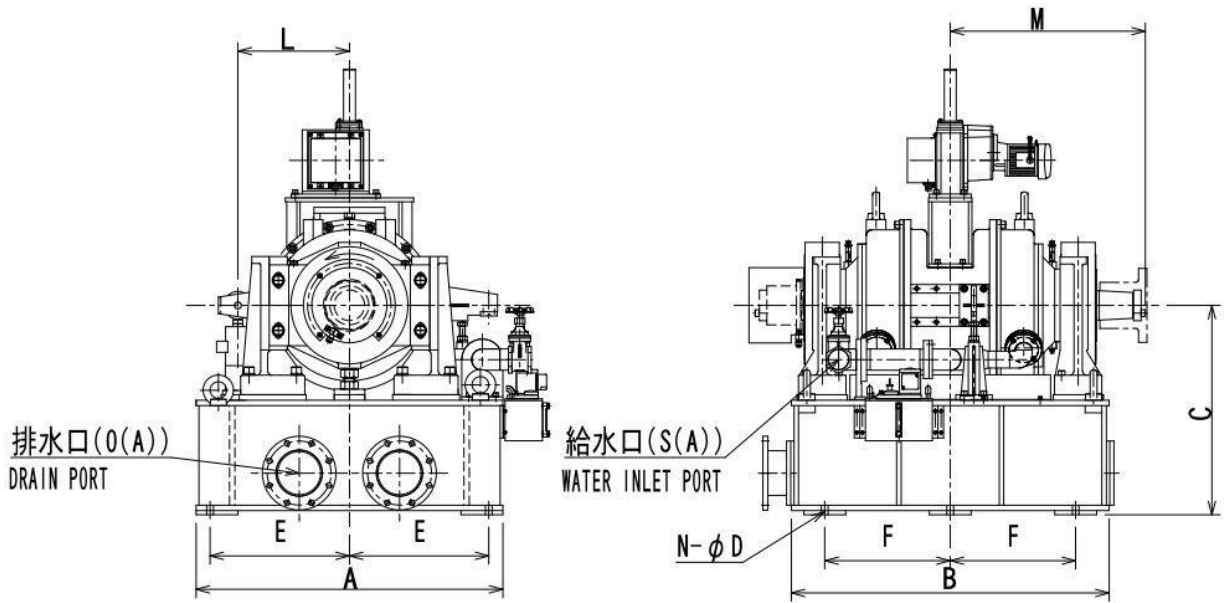

Model	Mass kg	Dimension									
		A	B	C	E	F	N-φD	L	M	S(A)	O(A)
PRS-30A	1,100	950	820	600	420	320	4-24	358.1	500	50	125
PRS-35A	1,550	1,100	940	650	500	350	4-24	400	600	50	150
PRS-40A	1,600	1,100	970	650	500	350	4-24	375	635	50	150
PRS-45A	2,100	1,100	1,060	750	500	425	6-24	430	680	65	150
PRS-55A	3,500	1,400	1,200	750	650	500	6-24	500	835	80	150
PRS-60A	4,700	1,700	1,300	950	815	600	6-24	680	970	80	200
PRS-70A	7,500	1,980	1,750	1,100				800	1,085	100	200

* Mass is determined by a stand and specification.

* Specification is subject to change due to product modification.

Standard Accessories	<ul style="list-style-type: none"> • Dyno main body, stand and load control remote controller • Bearing temp sensor • Inlet cooling water temp sensor • Outlet water temp sensor
Option (Chargeable)	<ul style="list-style-type: none"> • Dyno controller (manual or automatic control system) • Coupling flange on the dynamometer side • Calibration inspection tool (tool for dyno calibration) • Bearing height adjusting device (for centering work) • Centering bedplate (adjusting in X/Y/Z direction for centering work) • Rapid load variation device (the best option to the rapid load variation test) • Flowmeter for cooling water • Inlet water valve • Outlet water valve

■ Product range

OP type (irreversible type)

Best product range for the test of small to middle gasoline or diesel engines.

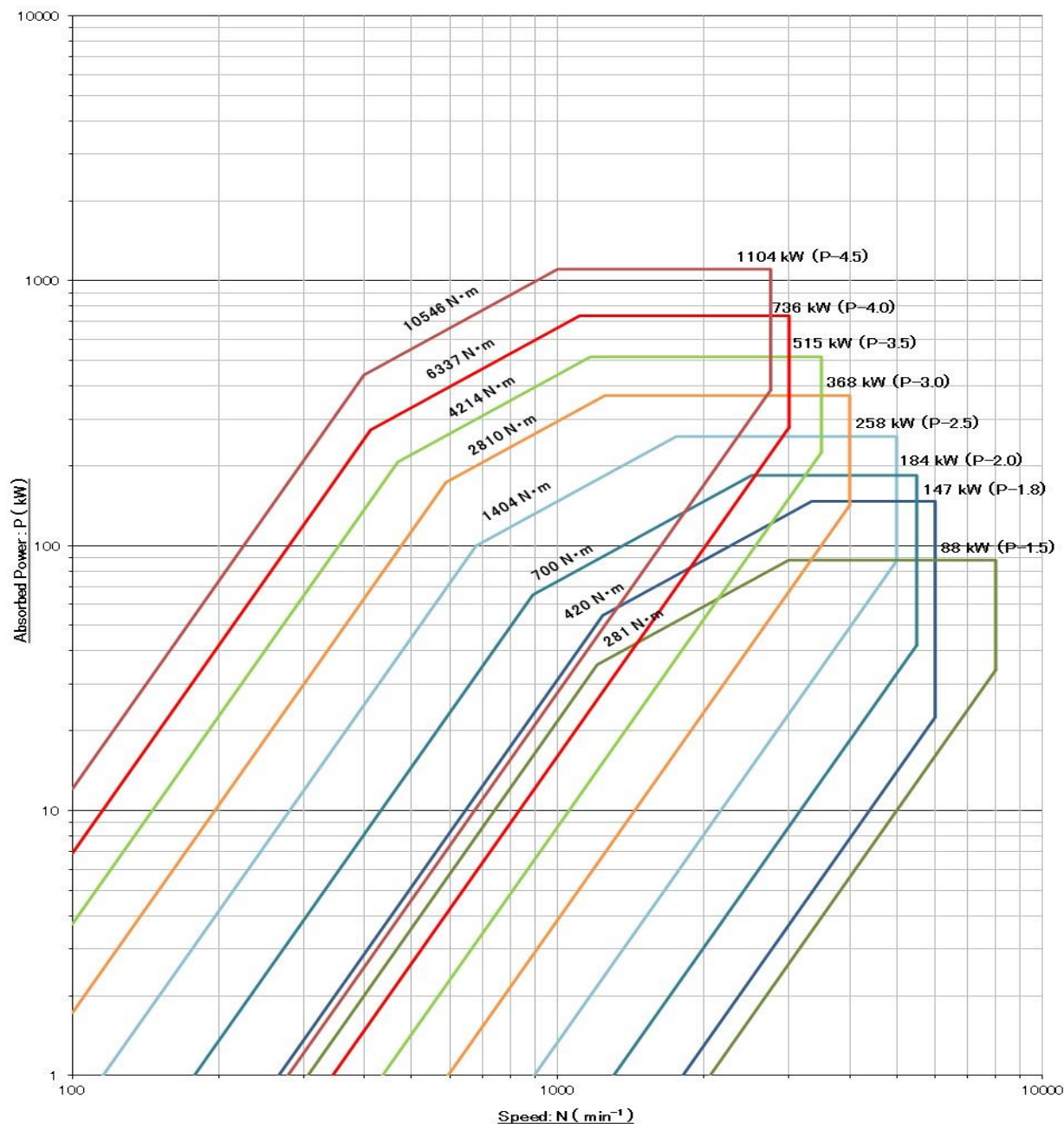

Model	Max. braking power kW	Max. braking torque Nm	Max. speed min ⁻¹	Constant torque range min ⁻¹	Inertia kg.m ²	Cooling water L/min
P-1.5	88	281	8,000	1,206~2,990	0.017	50
P-1.8	147	420	6,000	1,238~3,342	0.03	80
P-2.0	184	700	5,500	922~2,510	0.062	105
P-2.5	258	1,403	5,000	679~1,755	0.187	150
P-3.0	368	2,810	4,000	588~1,250	0.437	210
P-3.5	515	4,214	3,500	468~1,166	0.975	300
P-4.0	736	6,337	3,000	411~1,109	1.88	420
P-4.5	1,104	10,546	2,750	398~999	2.85	630

* Water flow: theoretical water flow when inlet water temp is 35° C and outlet water temp is 60° C.

* Specification is subject to change due to product modification.

■ Product range

OP type: Dry weight and dimension

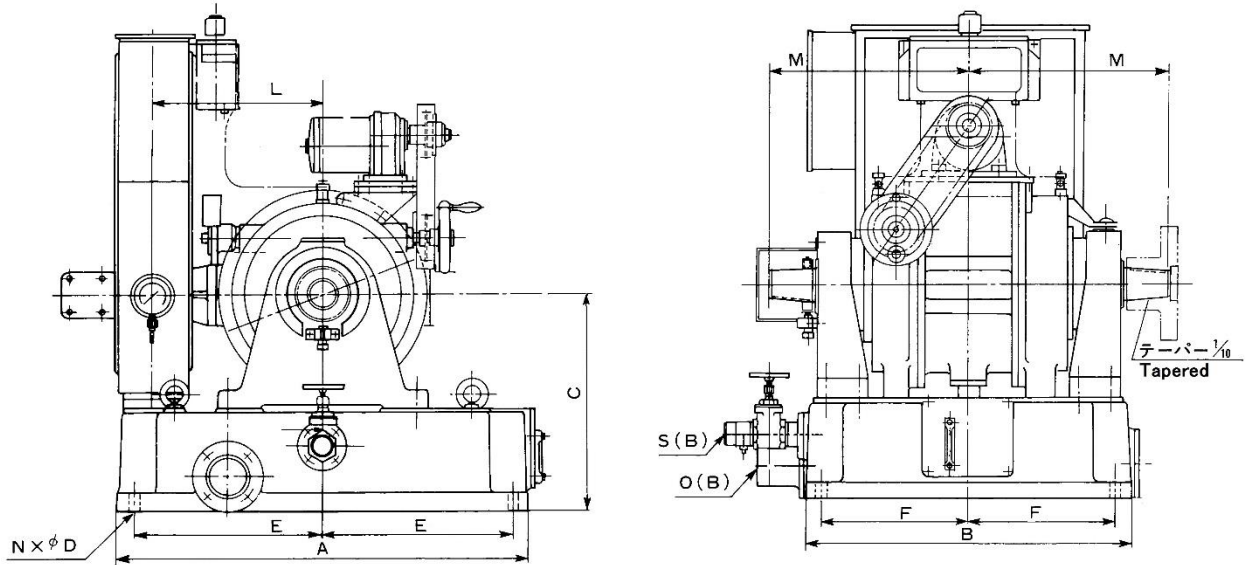

Model	Weight kg	Dimension									
		A	B	C	E	F	N-φD	L	M	S(B)	O(B)
P-1.5	150	505	396	260	325	140	4-17	239	248	¾	1¼
P-1.8	250	535	440	280	330	155	4-17	239	271	1	2
P-2.0	340	640	600	320	370	215	4-17	287	330	1	2
P-2.5	420	740	630	370	460	230	4-17	358	378	1	2
P-3.0	750	870	700	460	400	400	4-21	358	430	1½	3
P-3.5	1,350	1,010	860	550	620	330	4-21	478	550	1½	3
P-4.0	1,800	1,120	1,000	590	630	430	4-21	478	619	2	3
P-4.5	2,200	1,190	1,140	590	625	515	6-20	478	676	2	3½

* Mass is determined by a stand and specification.

* Specification is subject to change due to product modification.

Standard Accessories	<ul style="list-style-type: none"> • Dyno main body, stand and load control remote controller • Bearing temp sensor • Inlet cooling water temp sensor • Outlet water temp sensor
Option (Chargeable)	<ul style="list-style-type: none"> • Dyno controller (manual or automatic control system) • Coupling flange on the dynamometer side • Calibration inspection tool (tool for dyno calibration) • Bearing height adjusting device (for centering work) • Centering bedplate (adjusting in X/Y/Z direction for centering work) • Flowmeter for cooling water • Inlet water valve • Outlet water valve

■ Product range

○PRS type (reversible type)

Best product range for the test of small to middle gasoline or diesel engines.

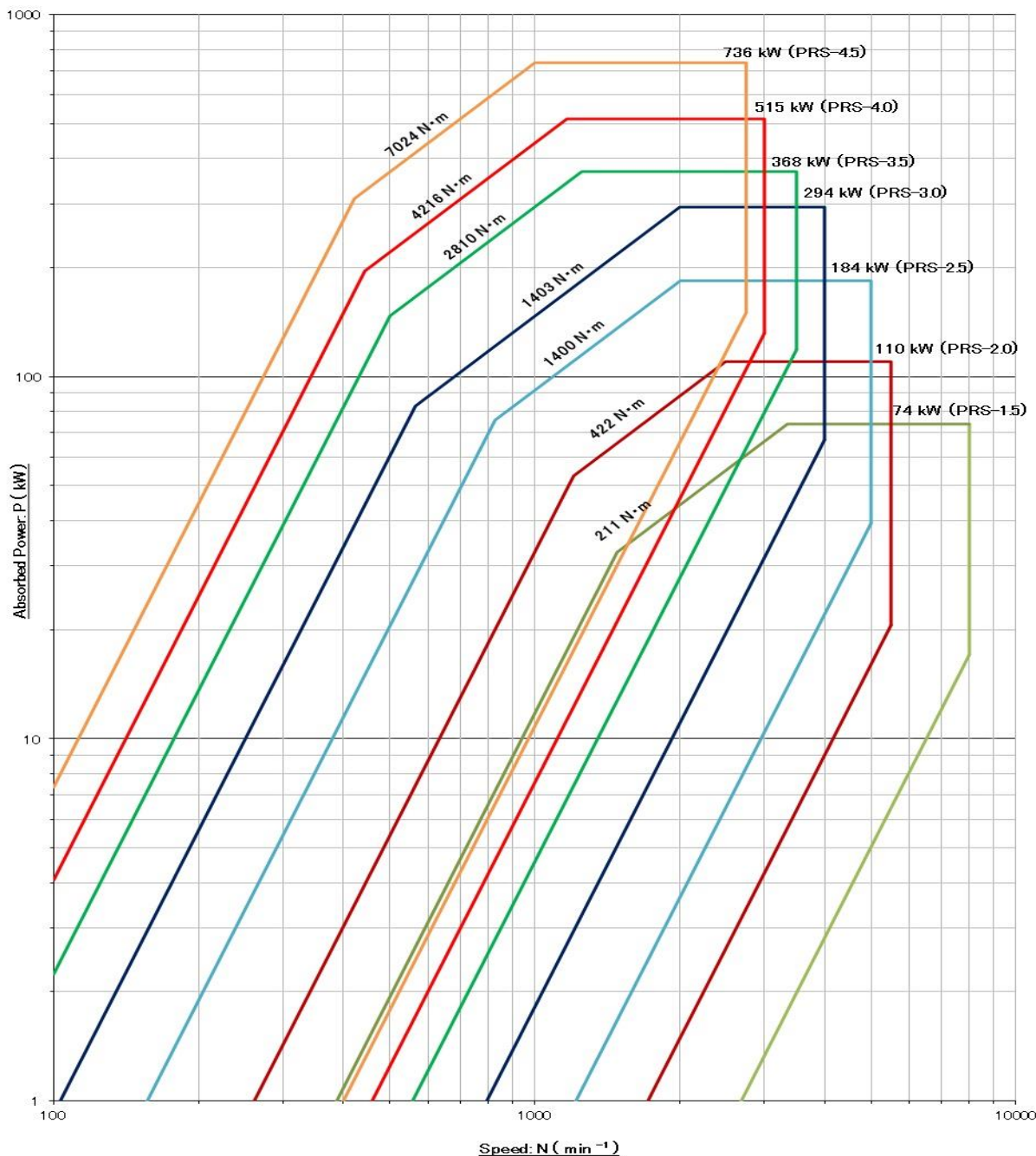

Model	Max. braking power kW	Max. braking torque Nm	Max. speed min ⁻¹	Constant torque range min ⁻¹	Inertia kg.m ²	Cooling water L/min
PRS-1.5	74	211	8,000	1,482~3,348	0.017	40
PRS-2.0	110	422	5,500	1,204~2,489	0.062	60
PRS-2.5	184	876	5,000	826~2,005	0.187	105
PRS-3.0	294	1,403	4,000	564~2,001	0.437	170
PRS-3.5	368	2,810	3,500	500~1,250	0.975	210
PRS-4.0	515	4,216	3,000	443~1,166	1.88	295
PRS-4.5	736	7,024	2,750	421~1,000	2.85	420

* Water flow: theoretical water flow when inlet water temp is 35° C and outlet water temp is 60° C.

* Specification is subject to change due to product modification.

■ Product range

OPRS type: Dry weight and dimension

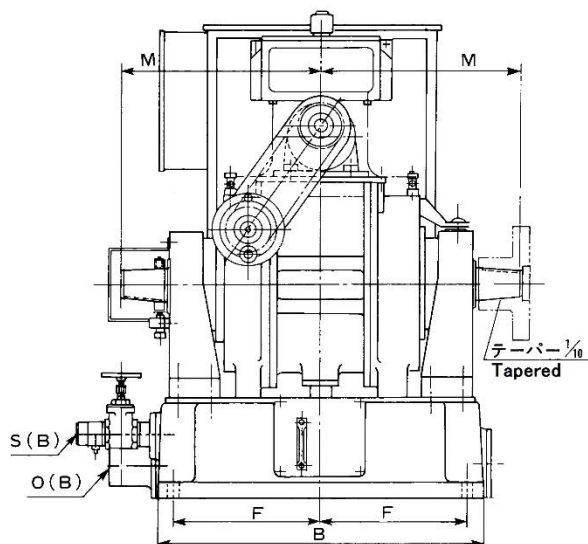
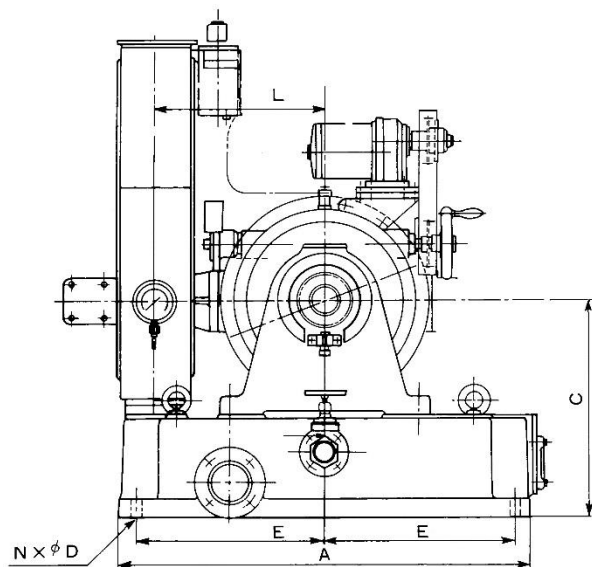

Model	Weight kg	Dimension									
		A	B	C	E	F	N-φD	L	M	S(B)	O(B)
PRS-1.5	150	505	396	260	325	140	4-17	239	248	¾	1¼
PRS-2.0	340	640	600	320	370	215	4-17	287	330	1	2
PRS-2.5	520	740	630	370	460	230	4-17	358	378	1	2
PRS-3.0	750	870	700	460	400	400	4-21	358	430	1½	3
PRS-3.5	1,350	1,010	860	550	620	330	4-21	478	550	1½	3
PRS-4.0	1,800	1,120	1,000	590	630	430	4-21	478	619	2	3
PRS-4.5	2,200	1,190	1,140	590	625	515	6-20	478	676	2	3½

* Mass is determined by a stand and specification.

* Specification is subject to change due to product modification.

Standard Accessories	<ul style="list-style-type: none"> • Dyno main body, stand and load control remote controller • Bearing temp sensor • Inlet cooling water temp sensor • Outlet water temp sensor
Option (Chargeable)	<ul style="list-style-type: none"> • Dyno controller (manual or automatic control system) • Coupling flange on the dynamometer side • Calibration inspection tool (tool for dyno calibration) • Bearing height adjusting device (for centering work) • Centering bedplate (adjusting in X/Y/Z direction for centering work) • Flowmeter for cooling water • Inlet water valve • Outlet water valve

■ Product range

○PHS type (irreversible type)

Best product range for the test of high speed turbine

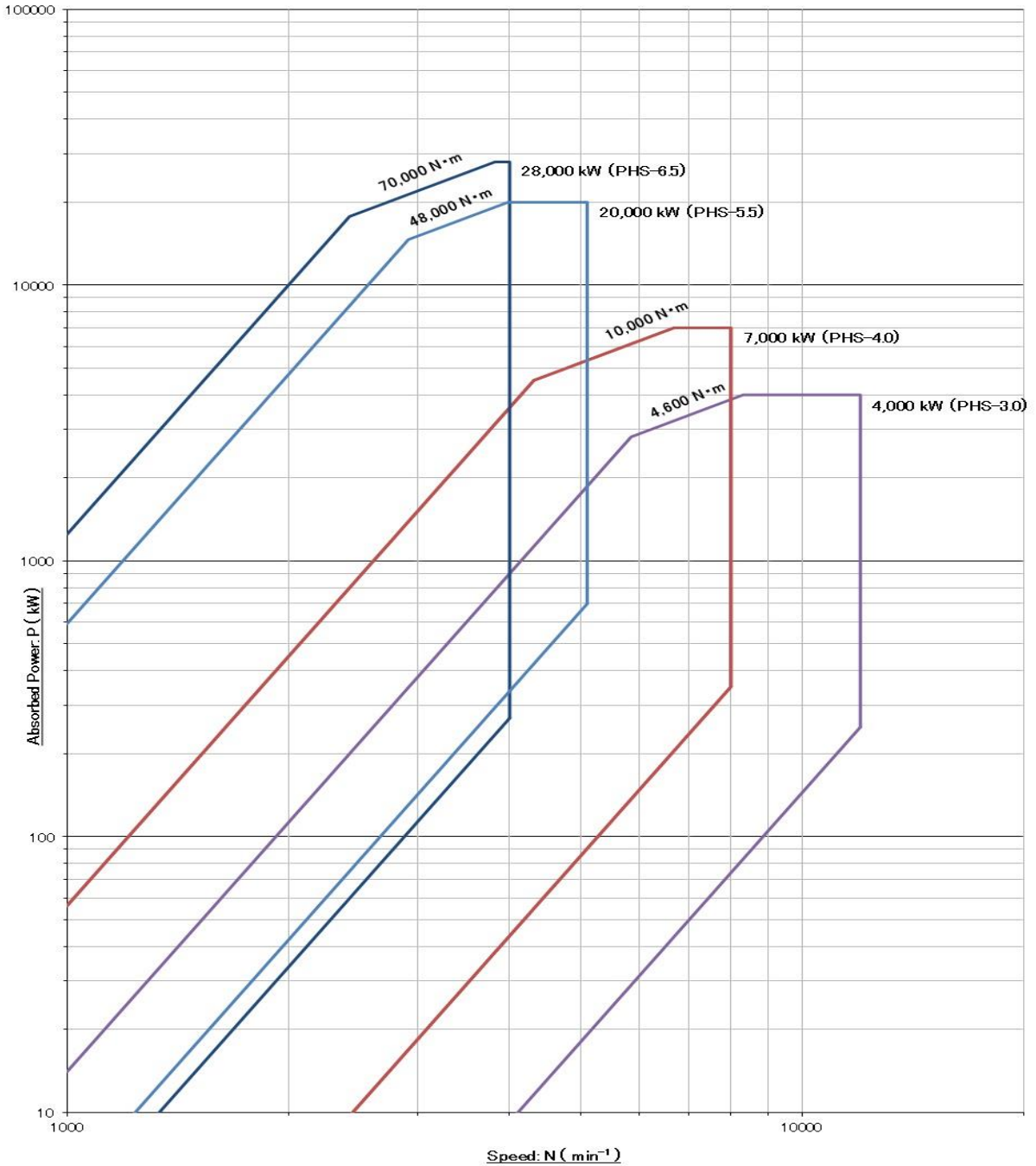

Model	Max. braking power kW	Max. braking torque Nm	Max. speed min ⁻¹	Constant torque range min ⁻¹	Inertia kg.m ²	Cooling water L/min
PHS-3.0	4,000	4,600	12,000	*	*	2,000
PHS-4.0	7,000	10,000	8,000	*	*	2,850
PHS-5.5	20,000	48,000	5,100	*	*	9,500
PHS-6.5	28,000	70,000	4,700	*	*	13,300

* Constant torque range: Based on the customers request.

* Inertia: Based on the customers request.

* Water flow: theoretical water flow when inlet water temp is 35° C and outlet water temp is 60° C.

* Specification is subject to change due to product modification.

Product range

OPHS type: Dry weight and dimension

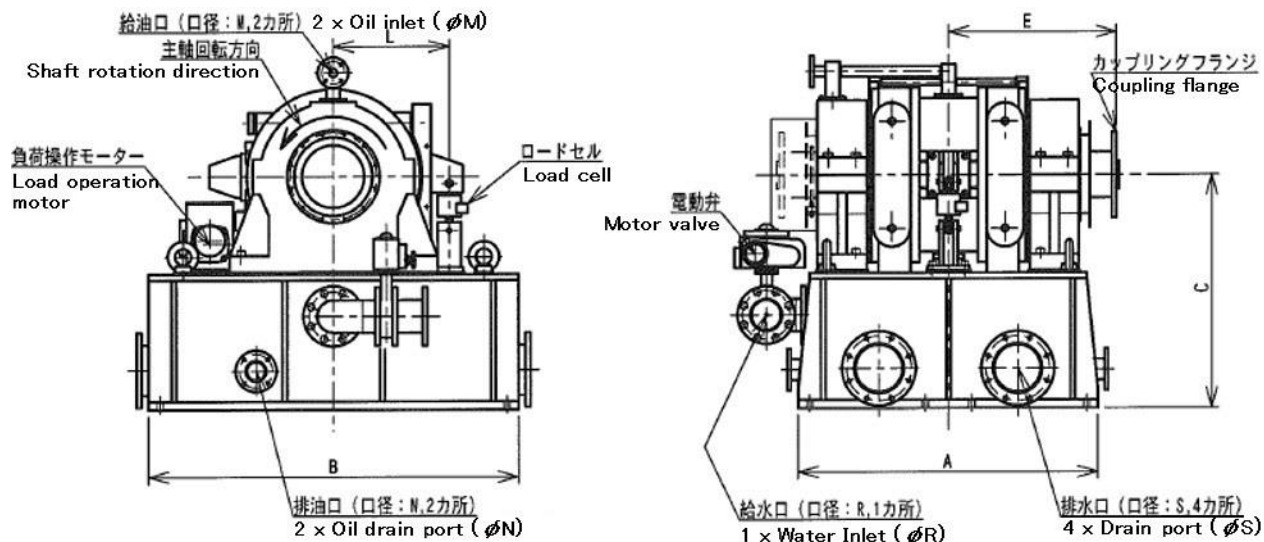

Model	Weight kg	Dimension								
		A	B	C	E	L	M	N	R	S
PHS-3.0	3,200	1,100	1,200	860	525	500	25A	50A	100A	200A
PHS-4.0	7,000	1,300	1,600	1,000	730	500	25A	80A	100A	200A
PHS-5.5	16,000	2,500	2,680	1,400	1,268	1,000	40A	80A	250A	300A
PHS-6.5	26,000	2,600	2,680	1,460	1,300	1,000	40A	80A	300A	300A

* Mass is determined by a stand and specification.

* Specification is subject to change due to product modification.

Standard Accessories	<ul style="list-style-type: none"> • Dyno main body, stand and load control remote controller • Bearing temp sensor • Inlet cooling water temp sensor • Outlet water temp sensor
Option (Chargeable)	<ul style="list-style-type: none"> • Dyno controller (manual or automatic control system) • Coupling flange on the dynamometer side • Calibration inspection tool (tool for dyno calibration) • Bearing height adjusting device (for centering work) • Centering bedplate (adjusting in X/Y/Z direction for centering work) • Flowmeter for cooling water • Inlet water valve • Outlet water valve

■ Product range

OPRD type (irreversible type)

Best product range for the test of large marine engine

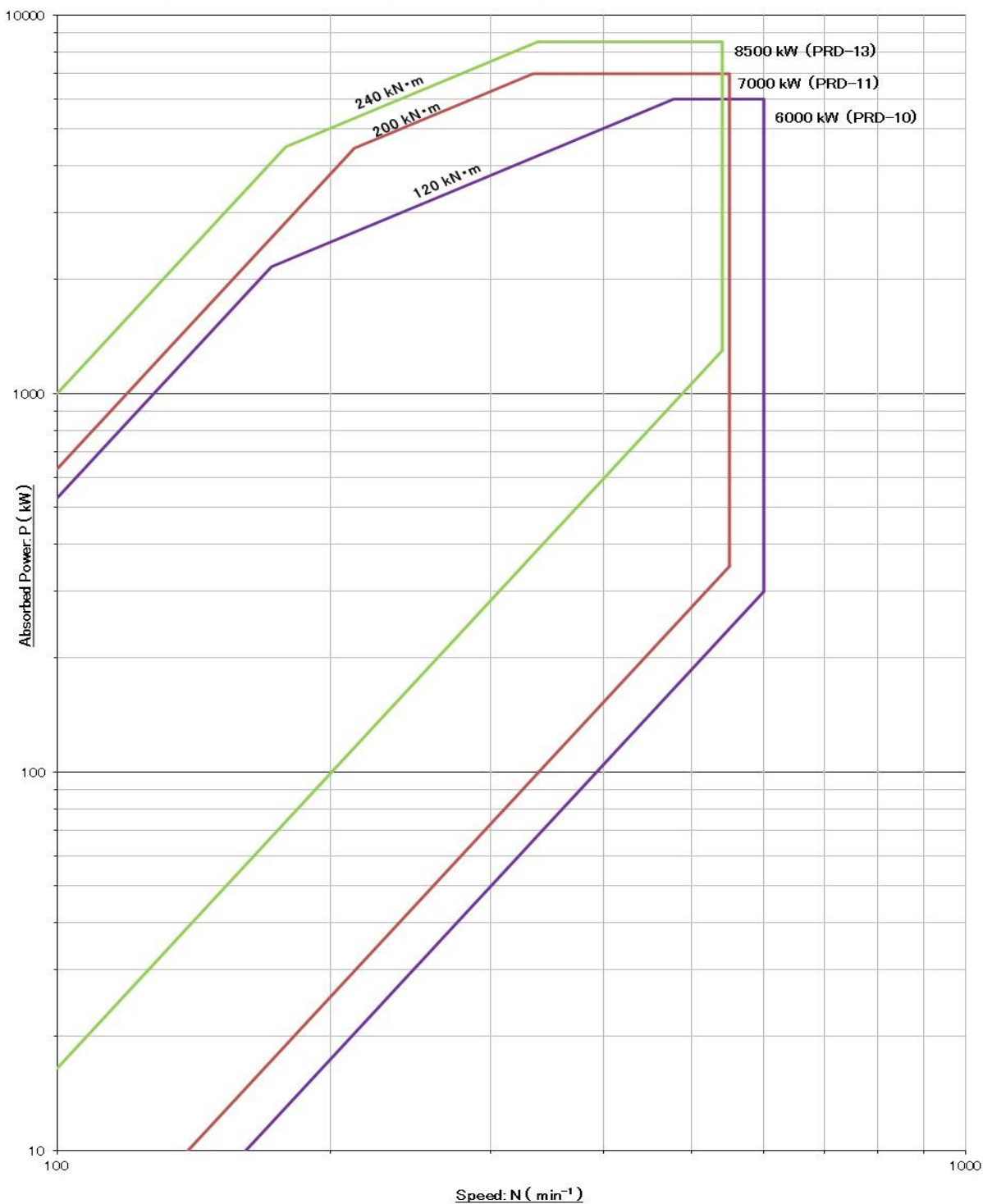

Model	Max. braking power kW	Max. braking torque kN.m	Max. speed min ⁻¹	Constant torque range min ⁻¹	Inertia kg.m ²	Cooling water L/min
PRD-10	6,000	120	600	172 to 477	237	2,870
PRD-11	7,000	200	550	212 to 334	484	3,350
PRD-13	8,500	240	540	178 to 338	770	4,060

* Water flow: theoretical water flow when inlet water temp is 35° C and outlet water temp is 60° C.

* Specification is subject to change due to product modification.

■ Product range

OPRD type: Dry weight and dimension

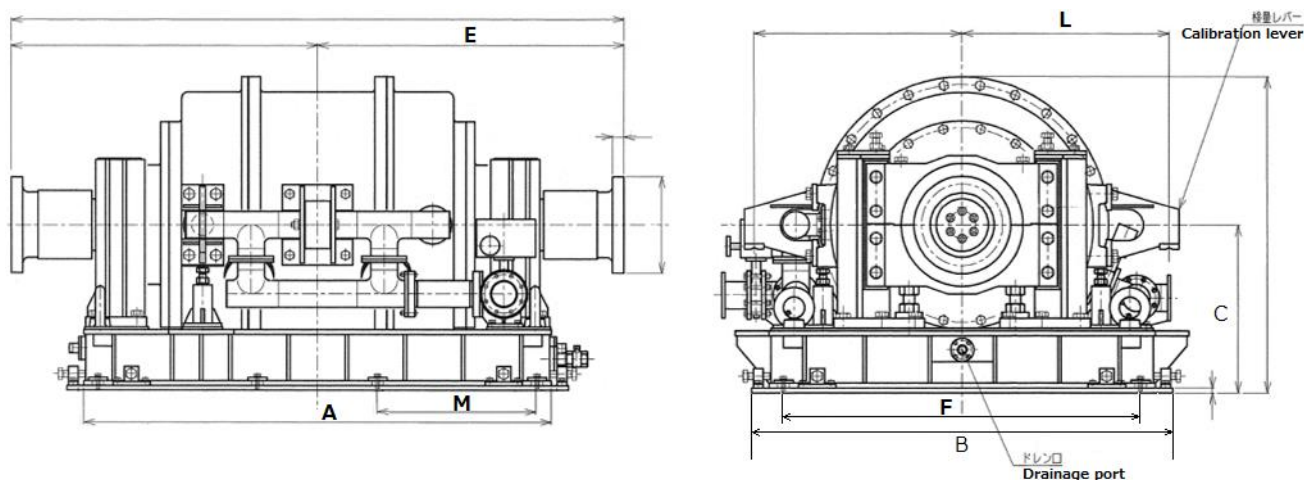

Model	Weight kg	Dimension									
		A	B	C	E	F	N-φD	L	M	S(B)	O(B)
PRD-10	9,000	2,100	1,750	770	1,420	1,600	14-φ24	1,000	700	125A	125A
PRD-11	17,500	2,452	2,000	860	1,575	1,850	8-φ24	1074.3	830	125A	125A
PRD-13	30,000	2,540	2,640	860	1,724	1,800	16-φ26	1,200	520	125A	125A

* Mass is determined by a stand and specification.

* Specification is subject to change due to product modification.

Standard Accessories	<ul style="list-style-type: none"> • Dyno main body, stand and load control remote controller • Bearing temp sensor • Inlet cooling water temp sensor • Outlet water temp sensor
Option (Chargeable)	<ul style="list-style-type: none"> • Dyno controller (manual or automatic control system) • Coupling flange on the dynamometer side • Calibration inspection tool (tool for dyno calibration) • Bearing height adjusting device (for centering work) • Centering bedplate (adjusting in X/Y/Z direction for centering work) • Flowmeter for cooling water • Inlet water valve • Outlet water valve

■ Optional product range

○ Dyno controller (automatic control)



This controller is dedicated for hydraulic dynamometer. It is a control measurement system that conduct measurement and feedback control by using hydraulic dynamometer. It is equipped with measurement function for speed and torque, control function for speed and torque of test piece by manual or automatic, and alarm function that detects and processes system malfunction.

○Main specification

Model	HDYC-400
Control mode	Manual control: Opening of load valve is adjusted by the manual encoder dial to control engine torque and speed. Constant speed control: Conducts feedback control to set speed. Constant torque control: Conducts feedback control to set torque. Marine property control: Calculates load from torque coefficient according to square of speed, then conducts cube control. External control: Receives programmed operation from an upper system to conduct control and measurement.
* Control accuracy	Control accuracy may not be within accuracy range due to the condition of engine and dyno, setting of PID adjustment and effect of cooling water pressure.
Alarm setting and monitoring	Emergency stop: Conducts control stop with emergency button when abnormal condition. Overspeed: Monitors the upper limit of the dyno maximum speed. Overload: Monitors the upper limit of the dyno maximum torque. Inlet water temp: Monitors the cooling water temp (35° C). Outlet water temp: Monitors the cooling water temp (60° C). Bearing temp: Monitors the bearing temp (80° C). External alarm: Alarm generates with contact signal input from external device.
External I/O	Analog voltage I/O (0-10V), analog current output (4-20mA), A contact signal
Necessary electric power	Three-phase AC200V, 50/60Hz, 15A
Dimension (mm)	Main body: W480 x H249 x D430 Mounted on rack: W520 x H543 x D600
Mass	Incl. main body, rack and power panel: approx. 50kg

* Specification is subject to change due to product modification.

* Please refer to the dyno controller catalog for the detail.

■ Optional product range

○Dyno controller (manual control)



This controller is a control measurement device to measure and control a test piece by using hydraulic power. This controller is equipped with measurement function for speed and torque, control function for speed and torque of test piece by manual operation, and alarm function that detects and processes system malfunction.

It can be operated very easily.

○Main specification

Model	TP-1000A
Manual operation	Manual load control: Push button controls the load operation motor and opens/closes the load valve to increase/decrease the absorbed torque.
Indicator accuracy	Speed indicator: Based on the indicator manufacturer. Torque indicator: Based on the indicator manufacturer. * Indicator accuracy may not be within accuracy range due to the condition of engine and dyno, setting of PID adjustment and effect of cooling water pressure.
Alarm setting and monitoring	Dyno oil lubrication: Monitors oil flow with galvanometer. When alarm generates, the position of engine throttle is switched to idling while keep pressing the load decrease button to the lower limit.
External I/O	Analog voltage I/O (0-10V), contact signal
Necessary electric power	Three-phase AC200V, 50/60Hz, 15A
Dimension (mm)	Main body: W480 x H249 x D430 Mounted on rack: W520 x H543 x D600
Mass	Main body: approx. 20kg (50kg when Incl. rack and power panel)

* Specification is subject to change due to product modification.

* Please refer to the dyno controller catalog for the detail.

■ Option

○ Automation System MORPHEE

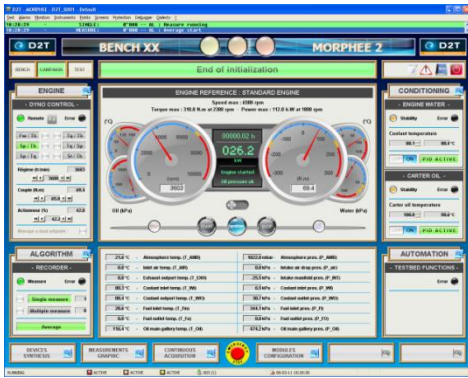

MORPHEE Main screen
(reference)

MORPHEE is implemented with basic functions of test bench data acquisition, programmed operation and test sequence setting, as well as integrating automation and ECU calibration, and real-time model execution in test bench. And it improves reliability of test in test bench and contributes to bench test, actual vehicle test and decreasing man-hour of calibration process. MORPHEE is developed and sold by FEV.

○ Data acquisition system (MIO module)



High robustness and high expandable I/O modules are expected in engine and drivetrain bench tests. Our data acquisition system can combine modules and I/O signal types (temp., pressure, analog, digital and contact) according to customers' needs.

○ Test bed utilities (optional)

We can offer a wide range of test bed utilities according to customer's needs. We also select the most suitable shaft couplings to reduce engine torsional vibration.



Engine mount, mobile common stand



CVJ, damper, adapter
Safety guard for joint

■ Related Products

○ Portable Hydraulic Dynamometer

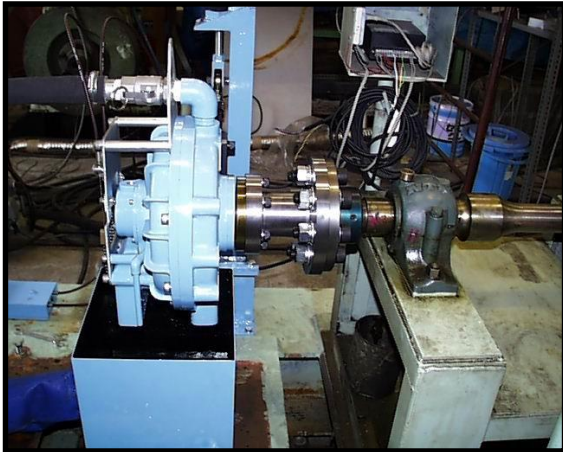

We are the only company that develops, designs, sells and manufactures portable hydraulic dynamometers in Japan, with the product range of 10 to 370 kW.

Our portable hydraulic dynamometers receive high recognition and are adopted in domestic and overseas due to high portability, low cost and engine load performance test.

Please see the portable hydraulic dynamometer catalog for more details.

■ Rental and Refurbished Products

○ Reduce initial cost

Rental and rebuild products are available to meet customers request.

【Customers' specific needs】

- Need a dynamometer immediately for urgent schedule.
- Budget is not fully acquired.
- Want to include in deductible expenses without capitalizing assets.

○ Rental

The longest period of 2 years

Stock: Please contact us for models and stock.

○ Refurbished products

Fully overhauled product (as good as new)

Warranty period of 1 year

* Coupling flange and frame need to be newly manufactured.

○ Calibration Certificate

We provide calibration certificate for dynamometers needed for ISO.

■ Turnkey Project

We have a partnership with architect offices and engineering companies. We can deal with the following requests. We can collaborate with you from the planning phase. Please do not hesitate to contact us.

Design/Construction work for Labs

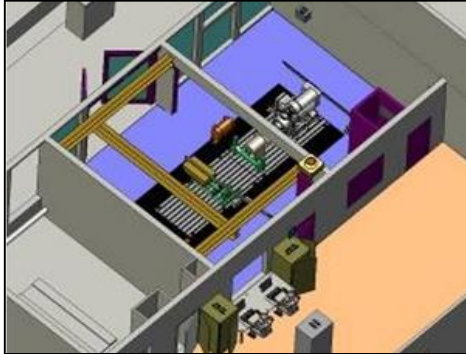

Samples:

- Test cell for gasoline engines
- Test cell for diesel engines
- Firing Bench of mass production line

Design/Construction Work for Test cells



Samples:

- Test cell for gasoline engine
- Test cell for diesel engines
- Firing Bench of mass production line

Test Cell Auxiliary Facilities



Samples:

Cooling tower, incoming panel, air-conditioning system, T-slot bedplate, custom silencer, intake/exhaust, fuel supply system, and etc.

Auxiliary Works



Workable items:

Delivery, installation, adjusting alignment, piping, wiring and etc.

■ Maintenance

Even a health enthusiast can roughly judge his/her body condition on the day. However, complete health condition cannot be known without medical help. For the testing devices, each component gets worn little by little as tests are repeated. And oil used to prevent wear as little as possible also gets worn and deteriorated according to frequency of use and elapsed time. Because testing machines don't have self-healing abilities, knowing the machine condition by periodic maintenance can maintain the best condition.

In order to have accurate data acquisition with testing devices, periodic maintenance is necessary.



■ Periodic maintenance prevents malfunctions.



In case a testing device is used under the severe condition, especially continuous durability test, bearings and sealings suffer faster; these need periodic replacement. After maintenance work, we in detail confirm the condition of products by calibration inspection, running inspection and etc before delivery. Testing devices which pass the rigid company criteria can be delivered to customers again.

■ Recommendation of periodic maintenance

In order to conduct accurate measured data acquisition in test benches, we recommend to have periodic inspection once or twice an year, aside from maintenance. Our engineers can visit your sites domestically and internationally.

* Periodic maintenance and inspection are charged.

■ Spare parts and calibration work

Dyno spare parts and sensors such as load cell and speed detector can be delivered. And also we calibrate load cells and indicators. Please contact us for further information.

* On-site work must be reserved.

■ Flow of Inquiry

Please do not hesitate to contact our sales by phone, email or web.

○ FAQ

Planning

Please tell us your planning about launching test cell or test bed and updating facilities.

Request for Quotation

Please tell us about application of dyno, test contents, engine specification, measurement items, test patterns and etc.

Request for Services

Please tell us product model and manufacturing number.

Technical Questions

Please tell us if you are concerned about our product structure and principle. Our sales will contact you.

Questions about Product

Please tell us if you are concerned about our product usage. Our sales will contact you.

Others

Please tell us if you have requests, opinions and concerns. Our sales will contact you.

We are responsible for handling customer information and inquiry contents as confidential.

【Contact】

Sales Group, Tokyo Plant Co., Ltd.

515-5 Miyazawa-cho, Akishima-city, Tokyo 196-0024

TEL: +81-(0)42-546-6500 FAX: +81-(0)42-546-6600

URL: www.tokyo-plant.co.jp

E-mail: sales@tokyo-plant.co.jp



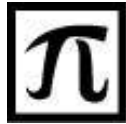

Since 1948