

Portable Hydraulic Dynamometer Product Catalog

■ Overview

We are the only company that develops, designs, sells and manufactures portable hydraulic dynamometers in Japan, Our portable hydraulic dynamometers receive high recognition and are adopted in domestic and overseas due to high portability, low cost and engine load performance test.



■ Product range

We have the widest range from 10kW to 500 kW.

■ Past Performance

Cumulative Number of machines: 500 and counting (No. 1 market share in Japan)

Destination: Japan and more than 10 countries

Major users: OEM (off-road, automobile), component supplier (Tier 1 ~), gas company, engine maintenance shop, JGSDF, universities, colleges of technology and research institutes

■ Major customers

TOYOTA, NISSAN, HONDA, Mitsubishi Motors, ISUZU, SUBARU, Yamaha Motor, Calsonic Kansei,, Aishin Seiki, Yanmar, Kubota, Mitsubishi Heavy Industries, Komatsu, Shimadzu, Hitachi, Kawasaki Heavy Industries, CAT, NGK, Riken, Cataler, Ibiden, Mitsui Engineering & Shipbuilding, Zenoah, Mitsuboshi Belting, Daido Kogyo, Bando Chemical Industries, Toho Gas, universities, colleges of technology, research institutes, racing teams and etc.

(Total of 200 companies)



■ Characteristics

<p>Low cost Easy operation</p>	<ul style="list-style-type: none"> • Directly connected to flywheel and motor shaft like engines. No need of centering work or shaft couplings according to test pieces. • Full range of measurement can be adjusted by setting water flow and handle operation. • Speed and torque employs digital indicator as standard. • Outputs analog voltages of speed and torque. • Connector is employed to prevent cable disconnection.
<p>Compact and lightweight</p>	<ul style="list-style-type: none"> • Space-saving inside test cell. • Light-weight and portable. Can be stored in a shelf when in not use.
<p>Options (Chargeable)</p>	<ul style="list-style-type: none"> • Automatic control system can conduct constant speed, constant torque and programmed operation control. • It can be also installed vertically. • T-slot bedplate is not needed because of the portable stand. If environmental regulation meets, it can be installed outside.

■ Principle and Structure

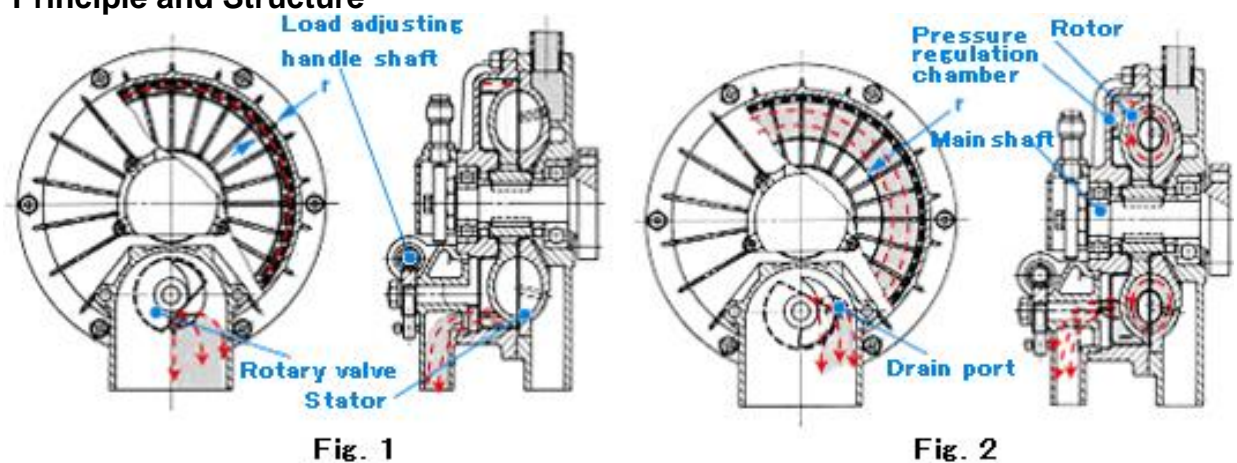

Fig. 1

Fig. 2

1. When water is supplied to a dynamometer driven by an engine, the water runs in the direction of the allows below. The engine output is absorbed by fluid friction generated inside impeller chamber. Fluid friction converts mechanical energy into thermal energy and raises the water temperature.
2. The braking torque is adjusted by moderating water resistance, which by changing the residing water amount inside impeller chamber. Tanaka's hydraulic dynamometer adjusts braking torque by rotating the rotary valve with a load control handle, varying the aperture area of the water outlet then varying water level R in radial direction inside the pressure regulating chamber.
3. Fig. 1 shows that when braking torque is at minimum, almost all water from the water inlet passes the impeller chamber and is discharged from the water outlet.
4. Fig. 2 shows that when braking torque is at medium, residing water in the impeller chamber is increased in proportion to the water level in radial direction compared with Fig. 1.

■ Applications

○ Targets

- Marine engine
- Agricultural machine engine
- Construction vehicle engine
- Generator
- Small turbine
- Pump
- Passenger cars
- Motor
- Truck engine
- Motorcycle engine
- Gear box

○ Tests

- Durability performance test
- Partial load performance test
- Full-open performance test
- Component evaluation test
- other performance tests (steady state)

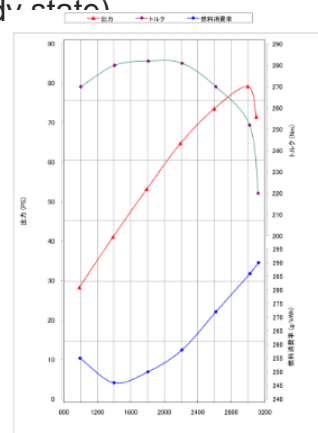

■ System Configuration

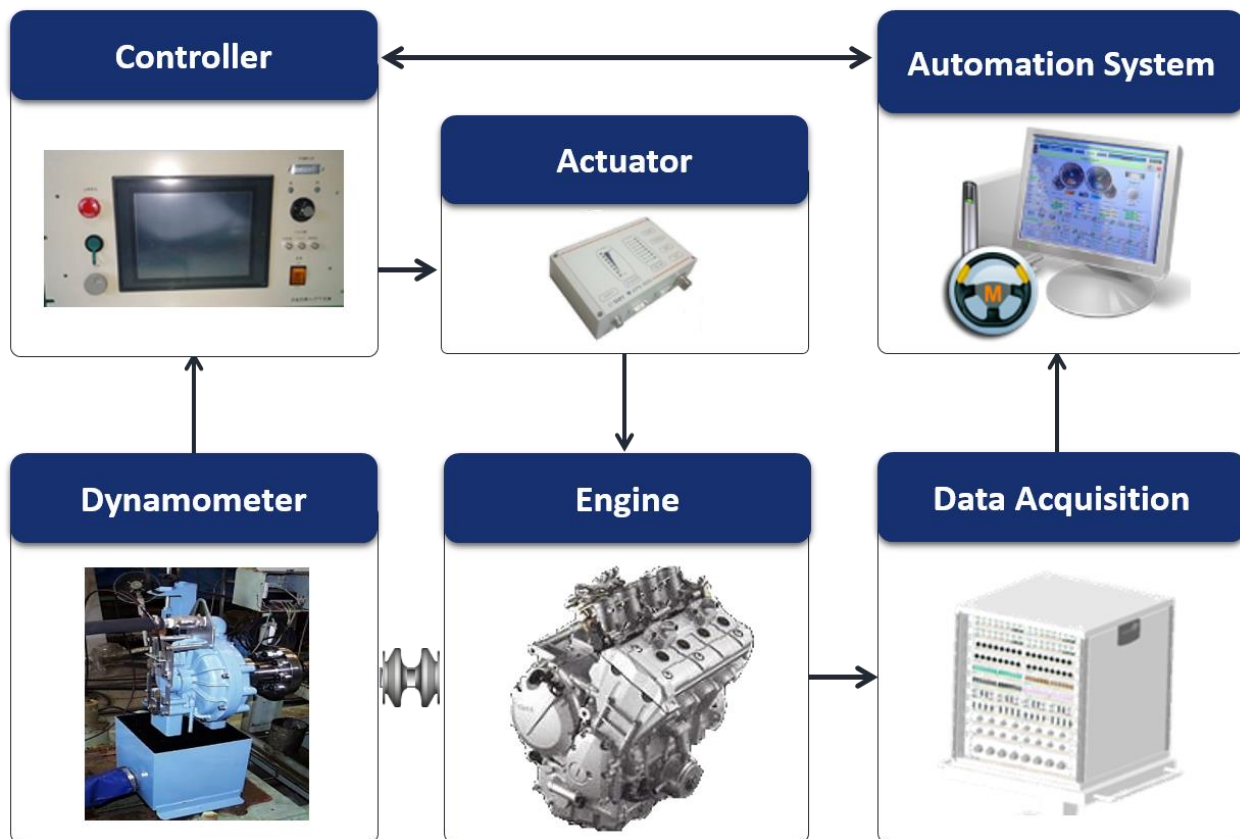

We can offer the most suitable testbed engineering to customers. Please contact us for further details about automation system, data acquisition sensors, testbed layout and shaft couplings. We can offer the suitable proposal for your budget and request.

■ Product range

OPRD type (irreversible type)

Best product range for the test of small to middle gasoline or diesel engines.

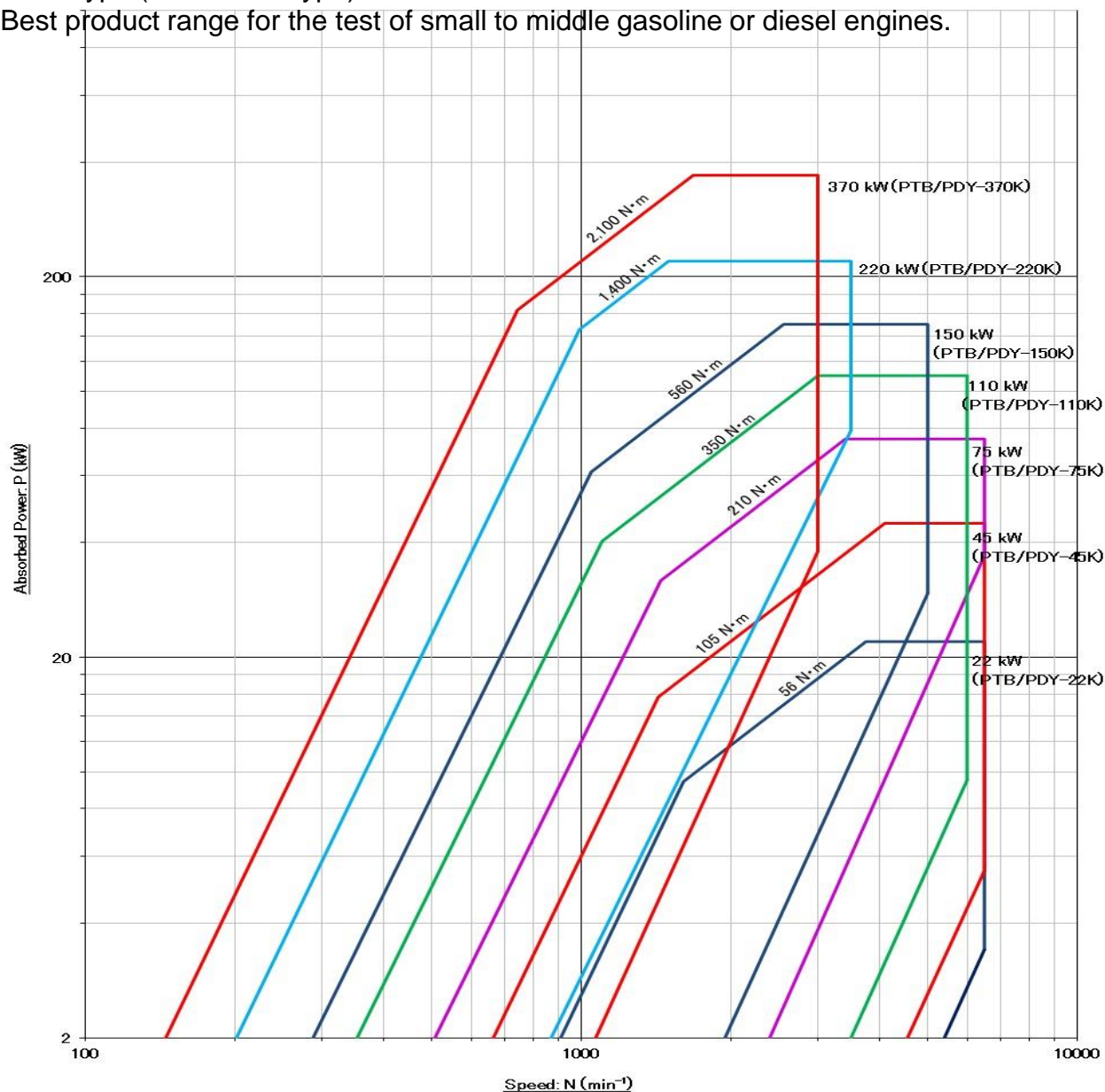

Model	Max. braking power kW	Max. braking torque Nm	Max. speed min ⁻¹	Constant torque range min ⁻¹	Inertia kg.m ²	Cooling water L/min
PTB-22K	22	56	6,500	1,610~3,750	0.0016	9
PTB-45K	45	105	6,500	1,430~4,090	0.0032	18
PTB-75K	75	210	6,500	1,450~3,410	0.006	30
PTB-110K	110	350	6,000	1,110~3,000	0.0107	45
PTB-150K	150	560	5,000	1,050~2,550	0.0325	60
PTB-220K	220	1,400	3,500	1,000~1,500	0.075	90
PTB-370K	370	2,100	3,000	750~1,680	0.17	150

* Difference between PTB and PDY: Fly wheel adapter can be mounted on PDY type.

* Water flow: theoretical water flow when inlet water temp is 25° C and outlet water temp is 60° C.

* Specification is subject to change due to product modification.

■ Product range

OPTB and PDY type: Dry weight and dimension

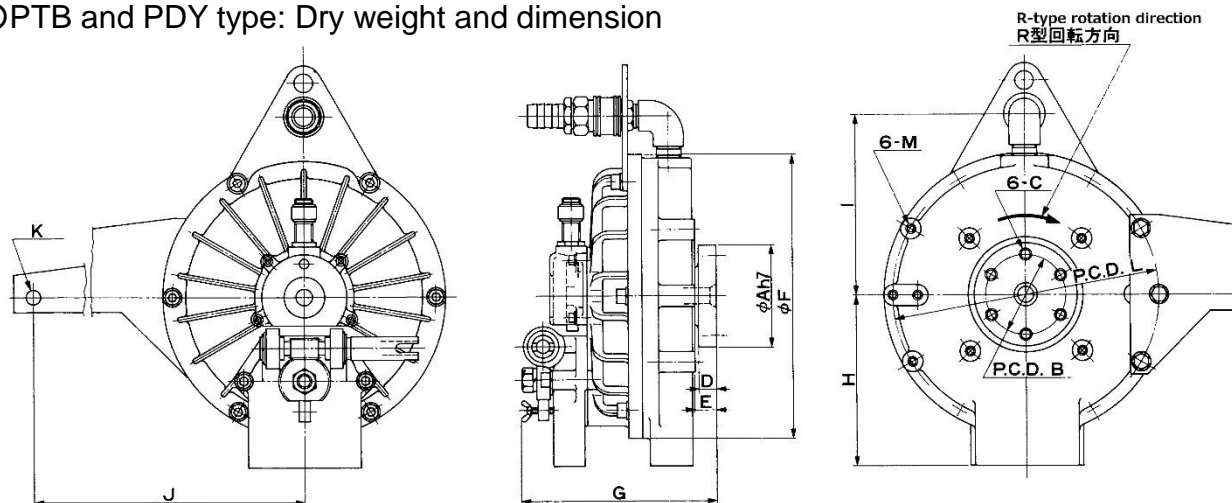

Model	Mass kg	Dimension (mm)												
		A	B	C	D	E	F	G	H	I	J	K	L	M
PTB-22K	7	80	60	M8 x 1.25	15	18	190	200	120	156	358.1	6.1	176	M6 x 1.0
PTB-45K	10	90	70	M10 x 1.5	15	18	218	213	132	169	358.1	6.1	200	M8 x 1.25
PTB-75K	12	90	70	M10 x 1.5	16	19	250	228	150	170	358.1	6.1	232	M8 x 1.25
PTB-110K	17	110	85	M10 x 1.5	16	20	300	250	180	196	358.1	6.1	280	M10 x 1.5
PTB-150K	23	130	110	M12 x 1.75	20	23	335	265	200	209	358.1	12.1	310	M12 x 1.75
PTB-220K	38	150	120	M16 x 2.0	25	30	416	320	230	275	500	12.1	386	M12 x 1.75
PTB-370K	70	180	145	M20 x 2.5	25	30	475	356	280	294	500	12.1	440	M16 x 2.0

* Mass is determined by a stand and specification.

* Specification is subject to change due to product modification.

Specification / Variation	A	B	C	D
1) Portable hydraulic dynamometer main body (standard specification)	○	○	○	○
2) Manual operated handle	○	○	○	○
3) Coupling flange on the dyno side	○	○	○	○
4) Rotation detector	○	○	○	○
5) Torque detector (load cell or torque flange) and mount	○	○	○	○
6) Intermediate bearing unit (optional)	△	△	△	△
7) Speed and load indicator, signal cables, power cable	○	○	○	
8) Remote load operation actuator		○		
9) Load operation hand-hold controller			○	
10) Dyno controller				○
11) Flywheel adapter (optional)	△	△	△	△

■ HDY type Portable Hydraulic Dynamometer

High speed type specification of 8,000 to 12,000 min⁻¹.

Output range of 10 to 120 kW.

Suitable for gasoline engine with high speed.

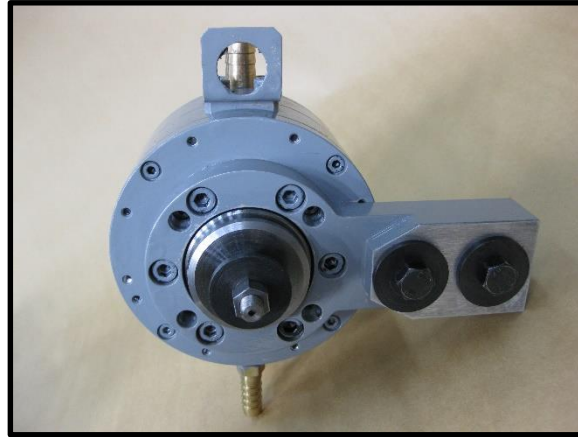

Manufacturing specification will be discussed with customer.

■ PDY Samples

○ Flywheel adapter (optional)

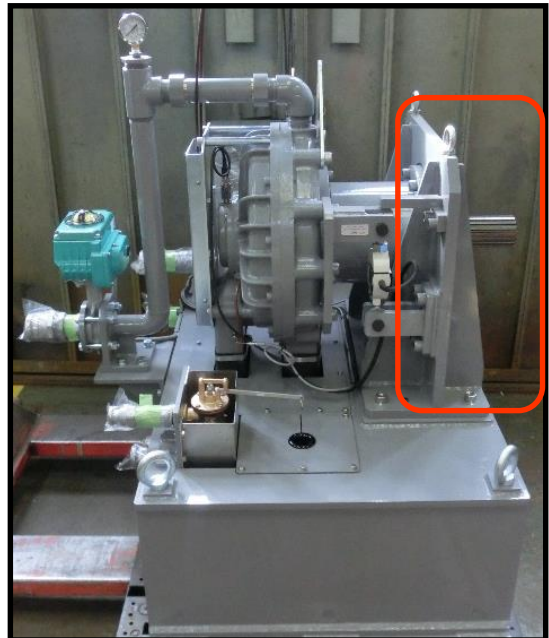

The red parts in the above pictures are connected to test pieces. Engine flywheel can be directly connected by attaching flywheel adapter as simplified testbed. It can reduce man-hour for bench setup such as engine installation and alignment work. * Some are not available due to engine specification. Initial cost for bench setup can be considerably reduced because T-slot bedplate is not needed.

* Please contact us for further information.

○ Portable operation bench

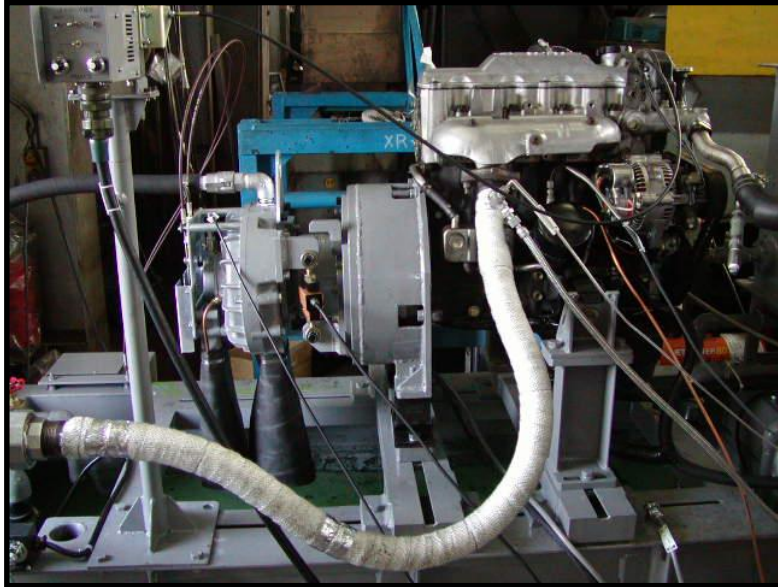

Portable type can be available by combining a portable hydraulic dynamometer and water tank with engine mount stand as simplified test bed. Initial cost for bench setup can be considerably reduced because T-slot bedplate is not needed. It is the best option to customers who want to conduct basic engine test (applying load) with low cost when they are difficult to install a cooling tower and test cell. It can be also used outside as portable type. Please note that environmental regulation must meets.

* Please refer to the portable test bed catalog.

○ Wheel type dynamometer



If you want to check the output of vehicle but chassis dynamometer cannot be introduced because of budget or space, portable hydraulic dynamometer and axle are directly connected as simplified vehicle test bed.

* Please contact us for further information.

■ Optional product range

○ Dyno controller (automatic control)



This controller is dedicated for hydraulic dynamometer. It is a control measurement system that conduct measurement and feedback control by using hydraulic dynamometer. It is equipped with measurement function for speed and torque, control function for speed and torque of test piece by manual or automatic, and alarm function that detects and processes system malfunction.

○ Main specification

Model	HDYC-400
Control mode	Manual control: Opening of load valve is adjusted by the manual encoder dial to control engine torque and speed. Constant speed control: Conducts feedback control to set speed. Constant torque control: Conducts feedback control to set torque. Marine property control: Calculates load from torque coefficient according to square of speed, then conducts cube control. External control: Receives programmed operation from an upper system to conduct control and measurement.
* Control accuracy	Control accuracy may not be within accuracy range due to the condition of engine and dyno, setting of PID adjustment and effect of cooling water pressure.
Alarm setting and monitoring	Emergency stop: Conducts control stop with emergency button when abnormal condition. Overspeed: Monitors the upper limit of the dyno maximum speed. Overload: Monitors the upper limit of the dyno maximum torque. Inlet water temp: Monitors the cooling water temp (35° C). Outlet water temp: Monitors the cooling water temp (60° C). Bearing temp: Monitors the bearing temp (80° C). External alarm: Alarm generates with contact signal input from external device.
External I/O	Analog voltage I/O (0-10V), analog current output (4-20mA), A contact signal
Necessary electric power	Three-phase AC200V, 50/60Hz, 15A
Dimension (mm)	Main body: W480 x H249 x D430 Mounted on rack: W520 x H543 x D600
Mass	Incl. main body, rack and power panel: approx. 50kg

* Specification is subject to change due to product modification.

* Please refer to the dyno controller catalog for the detail.

■ Optional product range

○Dyno controller (manual control)



This controller is a control measurement device to measure and control a test piece by using hydraulic power. This controller is equipped with measurement function for speed and torque, control function for speed and torque of test piece by manual operation, and alarm function that detects and processes system malfunction.

It can be operated very easily.

○Main specification

Model	TP-1000A
Manual operation	Manual load control: Push button controls the load operation motor and opens/closes the load valve to increase/decrease the absorbed torque.
Indicator accuracy	Speed indicator: Based on the indicator manufacturer. Torque indicator: Based on the indicator manufacturer. * Indicator accuracy may not be within accuracy range due to the condition of engine and dyno, setting of PID adjustment and effect of cooling water pressure.
Alarm setting and monitoring	Dyno oil lubrication: Monitors oil flow with galvanometer. When alarm generates, the position of engine throttle is switched to idling while keep pressing the load decrease button to the lower limit.
External I/O	Analog voltage I/O (0-10V), contact signal
Necessary electric power	Three-phase AC200V, 50/60Hz, 15A
Dimension (mm)	Main body: W480 x H249 x D430 Mounted on rack: W520 x H543 x D600
Mass	Main body: approx. 20kg (50kg when Incl. rack and power panel)

* Specification is subject to change due to product modification.

* Please refer to the dyno controller catalog for the detail.

■ Option

○ Automation System MORPHEE

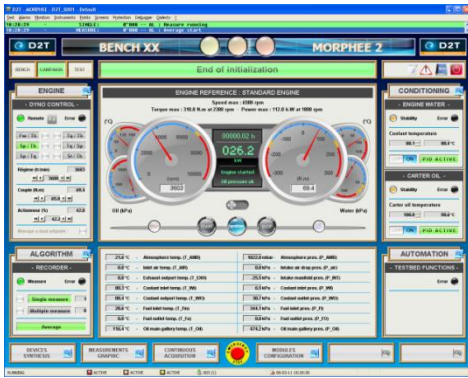

MORPHEE Main screen
(reference)

MORPHEE is implemented with basic functions of test bench data acquisition, programmed operation and test sequence setting, as well as integrating automation and ECU calibration, and real-time model execution in test bench. And it improves reliability of test in test bench and contributes to bench test, actual vehicle test and decreasing man-hour of calibration process. MORPHEE is developed and sold by FEV.

○ Data acquisition system (MIO module)



High robustness and high expandable I/O modules are expected in engine and drivetrain bench tests. Our data acquisition system can combine modules and I/O signal types (temp., pressure, analog, digital and contact) according to customers' needs.

○ Test bed utilities (optional)

We can offer a wide range of test bed utilities according to customer's needs. We also select the most suitable shaft couplings to reduce engine torsional vibration.



Engine mount, mobile common stand



CVJ, damper, adapter
Safety guard for joint

■ Related Products

○ Tanaka's Hydraulic Dynamometer

Tanaka's Hydraulic Dynamometer is a world representative hydraulic dynamometer. It has been introduced in many references, such as Automotive Engineering Handbook. It has great durability, high accuracy and low inertia. It has been introduced to many customers both domestically and internationally. We have a wide range of product; output range of 88 to 20,000 kW, low speed type, high speed type and high torque.

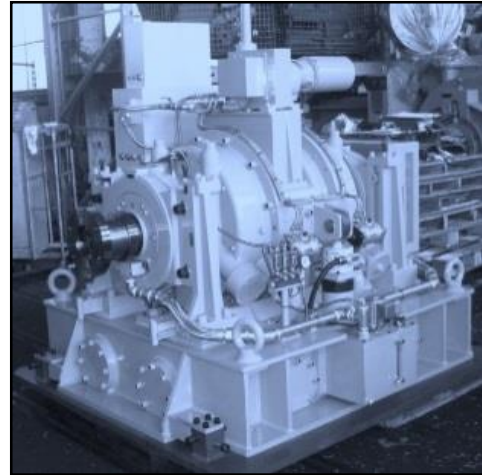

Please see the Tanaka's hydraulic dynamometer catalog for more details.

■ Rental and Refurbished Products

○ Reduce initial cost

Rental and rebuild products are available to meet customers request.

【Customers' specific needs】

- Need a dynamometer immediately for urgent schedule.
- Budget is not fully acquired.
- Want to include in deductible expenses without capitalizing assets.

○ Rental

The longest period of 2 years

Stock: Please contact us for models and stock.

○ Refurbished products

Fully overhauled product (as good as new)

Warranty period of 1 year

* Coupling flange and frame need to be newly manufactured.

○ Calibration Certificate

We provide calibration certificate for dynamometers needed for ISO.

■ Turnkey Project

We have a partnership with architect offices and engineering companies. We can deal with the following requests. We can collaborate with you from the planning phase. Please do not hesitate to contact us.

Design/Construction work for Labs

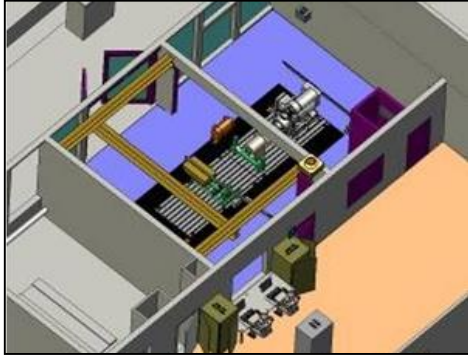

Samples:

- Test cell for gasoline engines
- Test cell for diesel engines
- Firing Bench of mass production line

Design/Construction Work for Test cells



Samples:

- Test cell for gasoline engine
- Test cell for diesel engines
- Firing Bench of mass production line

Test Cell Auxiliary Facilities



Samples:

Cooling tower, incoming panel, air-conditioning system, T-slot bedplate, custom silencer, intake/exhaust, fuel supply system, and etc.

Auxiliary Works



Workable items:

Delivery, installation, adjusting alignment, piping, wiring and etc.

■ Maintenance

Even a health enthusiast can roughly judge his/her body condition on the day. However, complete health condition cannot be known without medical help. For the testing devices, each component gets worn little by little as tests are repeated. And oil used to prevent wear as little as possible also gets worn and deteriorated according to frequency of use and elapsed time. Because testing machines don't have self-healing abilities, knowing the machine condition by periodic maintenance can maintain the best condition.

In order to have accurate data acquisition with testing devices, periodic maintenance is necessary.



STATOR

■ Periodic maintenance prevents malfunctions.



In case a testing device is used under the severe condition, especially continuous durability test, bearings and sealings suffer faster; these need periodic replacement. After maintenance work, we in detail confirm the condition of products by calibration inspection, running inspection and etc before delivery. Testing devices which pass the rigid company criteria can be delivered to customers again.

■ Recommendation of periodic maintenance

In order to conduct accurate measured data acquisition in test benches, we recommend to have periodic inspection once or twice an year, aside from maintenance. Our engineers can visit your sites domestically and internationally.

* Periodic maintenance and inspection are charged.

■ Spare parts and calibration work

Dyno spare parts and sensors such as load cell and speed detector can be delivered. And also we calibrate load cells and indicators. Please contact us for further information.

* On-site work must be reserved.

■ Flow of Inquiry

Please do not hesitate to contact our sales by phone, email or web.

○ FAQ

Planning

Please tell us your planning about launching test cell or test bed and updating facilities.

Request for Quotation

Please tell us about application of dyno, test contents, engine specification, measurement items, test patterns and etc.

Request for Services

Please tell us product model and manufacturing number.

Technical Questions

Please tell us if you are concerned about our product structure and principle. Our sales will contact you.

Questions about Product

Please tell us if you are concerned about our product usage. Our sales will contact you.

Others

Please tell us if you have requests, opinions and concerns. Our sales will contact you.

We are responsible for handling customer information and inquiry contents as confidential.

【Contact】

Sales Group, Tokyo Plant Co., Ltd.

515-5 Miyazawa-cho, Akishima-city, Tokyo 196-0024

TEL: +81-(0)42-546-6500 FAX: +81-(0)42-546-6600

URL: www.tokyo-plant.co.jp

E-mail: sales@tokyo-plant.co.jp



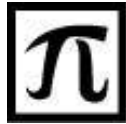

Since 1948