

t1000-1500 SERIES

ELASTOMER CLAW COUPLING



DESCRIPTION

The t1000-1500 has been especially developed for use in motor sport, two-wheel applications, and special applications, for example tests with dual mass flywheels or original vehicle clutches. This coupling is characterized by its relatively low weight, very robust design, high damping capability and easy maintenance.

The development aim of this coupling (to transfer very high alternating torques at low stiffness) was achieved in various different designs.

The design principle of the coupling allows the torsional stiffness to be adjusted for different requirements by using elastomers of varying hardness.

NAMING

The product is named according to the following convention:

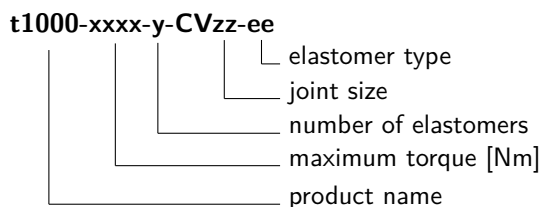

Example: *t1000-1500-1-CV15-SN*

OPERATING RANGE

Torque: up to 1500 Nm
Speed: up to 10000 rpm

BENEFITS

- for high dynamic loads
- fast exchange of the elastomer
- compact and modular design
- no elastomer failure when overloaded
- no shaft damage when elastomer fails
- high damping and long lifetime
- stiffness adjustment by elastomer placement

FUNCTION

The design provides a strongly non-linear coupling characteristic. The special design allows problem-free adaptation to new applications and a short downtime when exchanging the elastomers.



Exclusive Representative in Japan

 TOKYO PLANT Co., Ltd.
東京プラント株式会社

515-5 Miyazawa-cho, Akishima city, Tokyo, Japan 196-0024
TEL: +81-42-546-6500 FAX: +81-42-546-6600
Email: sales@tokyo-plant.co.jp

t1000-1500 SERIES

ELASTOMER CLAW COUPLING

t1000-1500		
Nominal torque ¹ T_{KN}	[Nm]	1500
Maximum torque T_{Kmax}	[Nm]	2450
Maximum alternating torque T_{KW}	[Nm]	950
Maximum speed	[rpm]	10000
Relative damping Ψ	[-]	0.1 - 0.35
Operating temperature for elastomer made of natural rubber ²	[°C]	80
Number of toothed ring teeth for speed measurement ³	[-]	64

Coupling	Joint	m	x_s	α_{max}	J_1	J_2	c_{Tdyn}
		[kg]	[mm]	[°]	[kgm ²]	[kgm ²]	[Nm/rad]
t1000-1500-1	CV15	3.24	29.8	7.5	3.67E-03	6.87E-03	2000 - 12000
t1000-1500-2	CV15	4.99	46.4	15.0	5.61E-03	1.06E-02	1000 - 6000
	CV21	5.31	48.1	15.0	6.58E-03	1.20E-02	1000 - 6000
t1000-1500-3	CV15	6.74	62.5	22.5	7.59E-03	1.52E-02	670 - 4000

m - Mass

x_s - Center of gravity flange-side

c_{Tdyn} - Torsional stiffness

α_{max} - Maximum torsional angle

J_1 - Inertia flange-side

J_2 - Inertia shaft-side

Elastomer type	Material	Shore hardness
HN	Natural rubber	45 - 50° Shore A
EN		50 - 55° Shore A
WN		53 - 58° Shore A
NN		63 - 68° Shore A
SN (Standard)		73 - 78° Shore A
UN		83 - 88° Shore A

¹The nominal torque must be equal to or greater than the maximum combustion engine torque

²Silicone elastomers for higher temperatures are available on request

³Toothed rings for rotational speed measurement available as an option

t1000-1500 SERIES

ELASTOMER CLAW COUPLING

Elastomer type	t1000-1500-1			t1000-1500-2			t1000-1500-3		
	cp ₁ [Nm/rad]	cp ₃ [Nm/rad ³]	Ψ [-]	cp ₁ [Nm/rad]	cp ₃ [Nm/rad ³]	Ψ [-]	cp ₁ [Nm/rad]	cp ₃ [Nm/rad ³]	Ψ [-]
HN	1857	326860	0.10	929	40858	0.10	619	12106	0.10
EN	2339	388778	0.10	1169	48597	0.10	780	14399	0.10
WN	3086	405231	0.15	1543	50654	0.15	1029	15009	0.15
NN	3599	674229	0.25	1799	84279	0.25	1200	24971	0.25
SN	5286	871735	0.30	2643	108967	0.30	1762	32286	0.30
UN	7422	1704387	0.35	3711	213048	0.35	2474	63125	0.35

cp₁ - Linear stiffness coefficient

cp₃ - Non-linear stiffness coefficient

Ψ - Relative damping

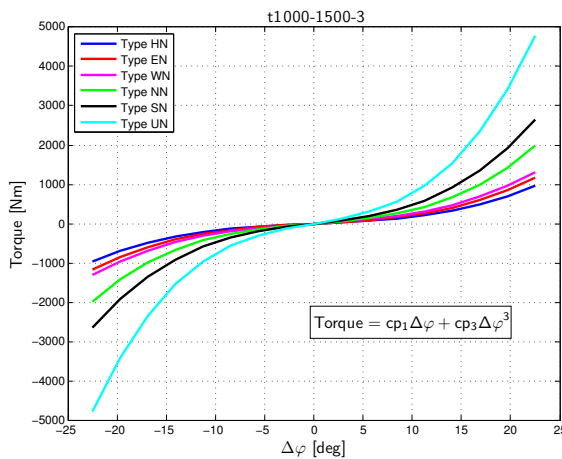
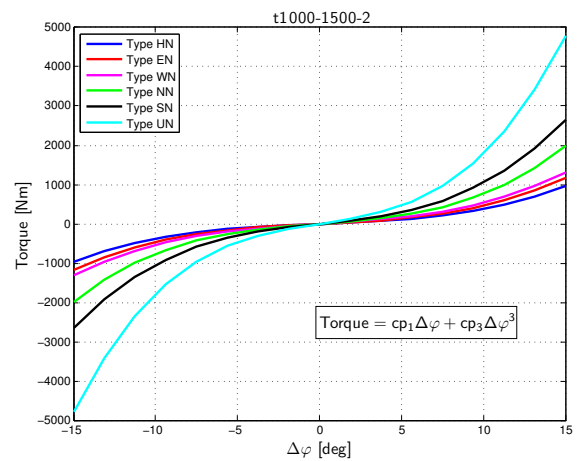
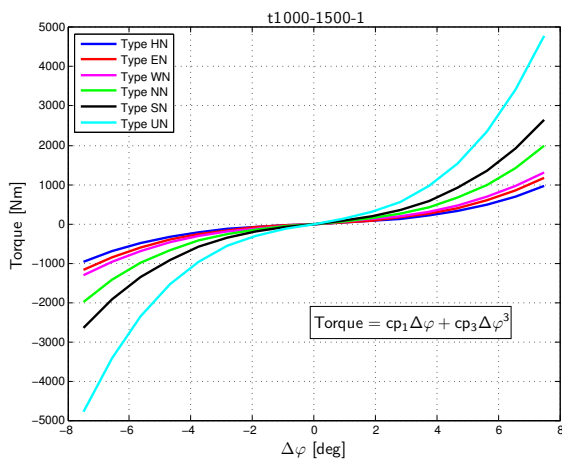

t1000-1500 SERIES

ELASTOMER CLAW COUPLING

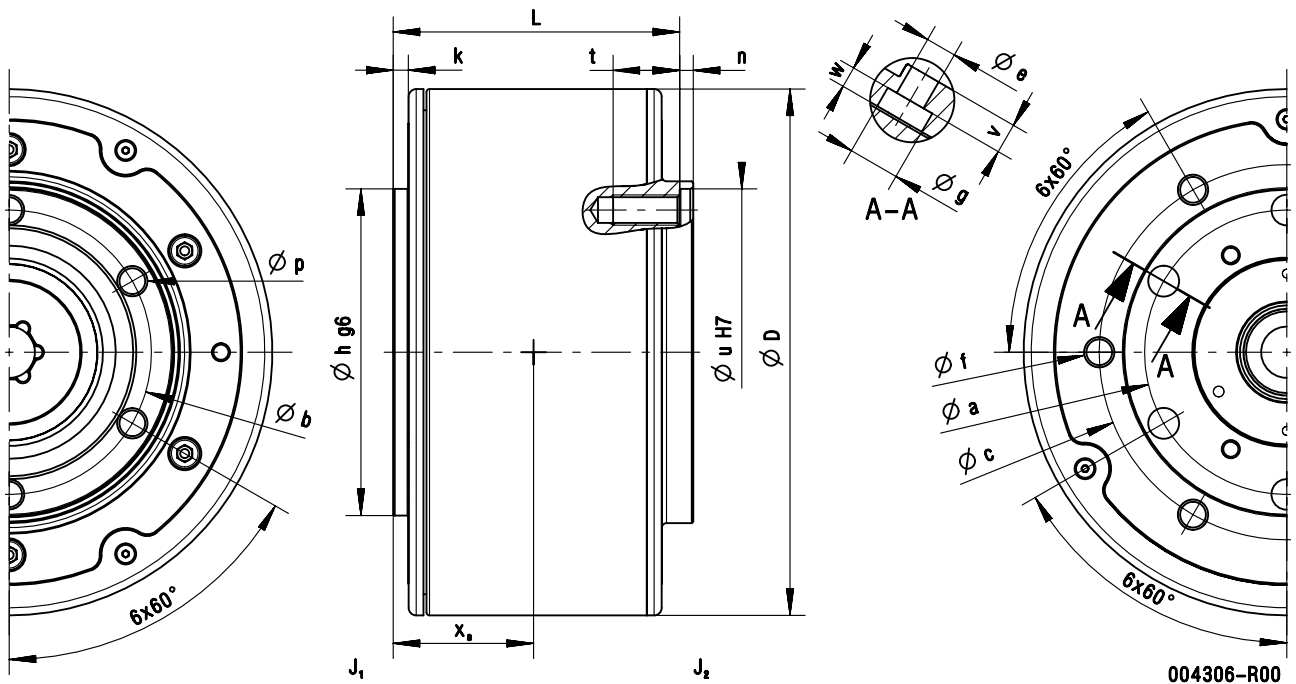

Coupling	Joint	D	L	a	b	c	e	f	g	h (g6)	k	n	p	t	u (H7)	v	w
		[mm]	[mm]	[mm]	[mm]	[mm]	[mm]	[-]	[mm]	[mm]	[mm]	[mm]	[-]	[mm]	[mm]	[mm]	[mm]
t1000-1500-1	CV15	174	62.6	94	94	124	10.2	M10	17	108	5	4.5	M10	22	108	10.0	7.0
t1000-1500-2	CV15	174	94.7	94	94	124	10.2	M10	17	108	5	4.5	M10	22	108	10.0	7.0
	CV21	174	100.7	108	108	-	13.0	-	20	128	6	5.5	M12	31	128	11.4	7.6
t1000-1500-3	CV15	174	126.8	94	94	124	10.2	M10	17	108	5	4.5	M10	22	108	10.0	7.0

Other dimensions available on request

2018-01-18 <6ec3b42950266036d110b045ec48520d2e5f040d> DS EN 11