

t650 SERIES

ELASTIC COUPLING



DESCRIPTION

The t650 was designed for testing engines of commercial vehicles and heavy duty applications. This coupling is characterized by its low weight, high damping and low maintenance requirements.

NAMING

The product is named according to the following convention:

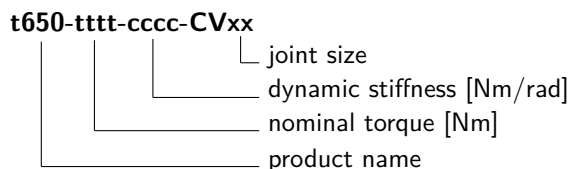

Example: t650-2500-5200-CV21

OPERATING RANGE

Torque: up to 8000 Nm
Speed: up to 5000 rpm

BENEFITS

- weight optimized design
- high damping
- low maintenance
- modular design

FUNCTION

As with all tectos drive shaft systems, the t650 follows a modular design principle, which separates the different functions.

The elastic part of the drive shaft connection is used to decouple and damp the torsional vibrations.

The modular design consisting of a stable bearing cartridge, the customer-specific adapter flange and the elastomer, allows assemblies with the most diverse specifications to be configured in a modular manner.

The standard t650 specifications cover a nominal torque range of 2500 - 8000 Nm for a torsional stiffness of 5200 - 25000 Nm/rad.



Exclusive Representative in Japan

 TOKYO PLANT Co., Ltd.
東京プラント株式会社

515-5 Miyazawa-cho, Akishima city, Tokyo, Japan 196-0024
TEL: +81-42-546-6500 FAX: +81-42-546-6600
Email: sales@tokyo-plant.co.jp

t650 SERIES

ELASTIC COUPLING

Coupling	Joint	T _{KN} [Nm]	C _{Tdyn} [Nm/rad]	T _{Kmax} [Nm]	T _{KW} [Nm]	n _{max} [rpm]	m [kg]	x _s [mm]	J ₁ [kgm ²]	J ₂ [kgm ²]	Ψ [-]
t650-2500-5200	CV21	2500	5200	7500	850	5000	16.06	47.3	1.13E-01	6.42E-02	0.4
	CV30	2500	5200	7500	850		16.43	46.8	1.16E-01	6.89E-02	
t650-3500-11000	CV21	3500	11000	10500	1100		17.34	52.2	9.32E-02	7.44E-02	
	CV30	3500	11000	10500	1100		17.73	47.4	9.62E-02	7.94E-02	
	CV32	3500	11000	10500	1100		16.88	48.3	9.63E-02	7.86E-02	
t650-4000-14500	CV30	4000	14500	12000	1200		19.14	50.9	1.07E-01	8.89E-02	
	CV32	4000	14500	12000	1200		17.98	51.0	1.08E-01	8.61E-02	
t650-5000-15700	CV32	5000	15700	15000	1650		25.48	44.0	3.28E-01	1.49E-01	0.6
t650-8000-24500	CV32	8000	24500	24000	2600		35.05	67.5	4.98E-01	2.25E-01	0.4

T_{KN} - Nominal torque¹
C_{Tdyn} - Torsional stiffness
T_{Kmax} - Maximum torque

T_{KW} - Maximum alternating torque
n_{max} - Maximum speed
m - Mass

x_s - Center of gravity flange-side
J₁ - Inertia flange-side
J₂ - Inertia shaft-side

Ψ - Relative damping

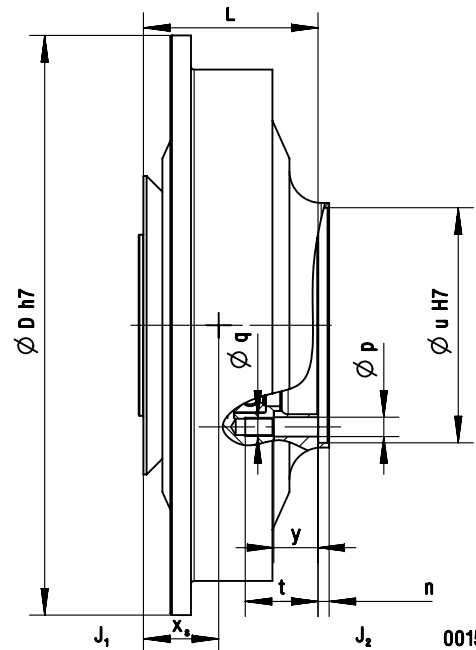
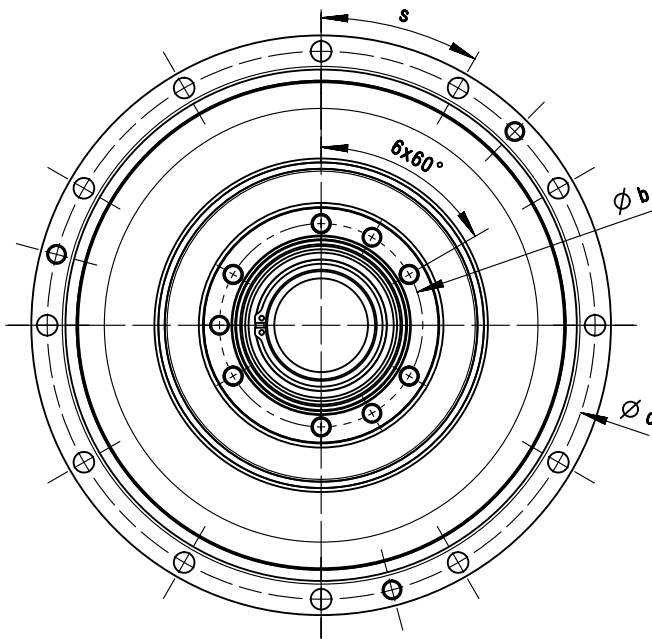

001530-R03

Coupling	Joint	D (h7) [mm]	L [mm]	b [mm]	c [mm]	n [mm]	p [mm]	q [mm]	s [°]	t [mm]	u (H7) [mm]	y [mm]	SAE type
t650-2500-5200	CV21	388	108.15	108	370	7	12.2	M12	16×22.5°	53.30	128	23.00	BCD
	CV30	388	108.62	128	370	6.4	12.2	M12	16×22.5°	44.50	148	26.50	BCD
t650-3500-11000	CV21	365	108.15	108	345	7	12.2	M12	12×30°	53.30	128	23.00	ABCDHIJ
	CV30	365	109.95	128	345	7	12.2	M12	12×30°	45.83	148	27.83	ABCDHIJ
	CV32	365	114.30	155.5	345	7	16.2	M16	12×30°	62.15	180	30.15	ABCDHIJ
t650-4000-14500	CV30	365	111.92	128	345	7	12.2	M12	12×30°	47.80	148	29.80	BCDJ
	CV32	365	114.30	155.5	345	7	16.2	M16	12×30°	62.15	180	30.15	BCDJ
t650-5000-15700	CV32	466.7	114.00	155.5	438.2	7	16.2	M16	16×22.5°	61.85	180	29.85	-
t650-8000-24500	CV32	466.7	114.00	155.5	438.2	7	16.2	M16	16×22.5°	61.85	180 H7	29.85	EFG

Other dimensions available on request

¹The nominal torque must be equal to or greater than the maximum combustion engine torque

t650 SERIES

ELASTIC COUPLING

SAE ADAPTER

The t650 is provided with an application-specific adapter. The dimensions on the t650 side are always tailored to the coupling (see the right-hand side of the figure),

whereas the dimensions on the connecting side vary according to customer-specific requirements.

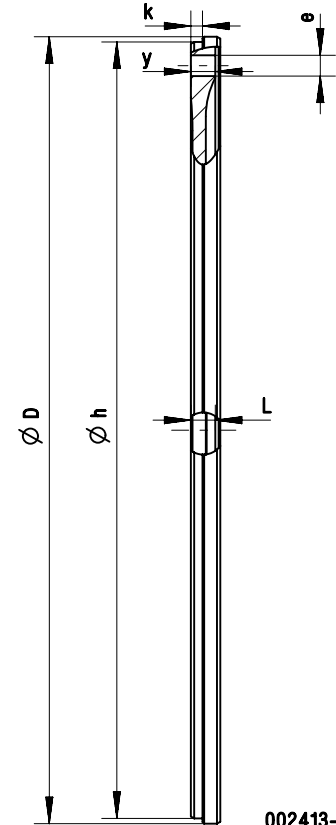
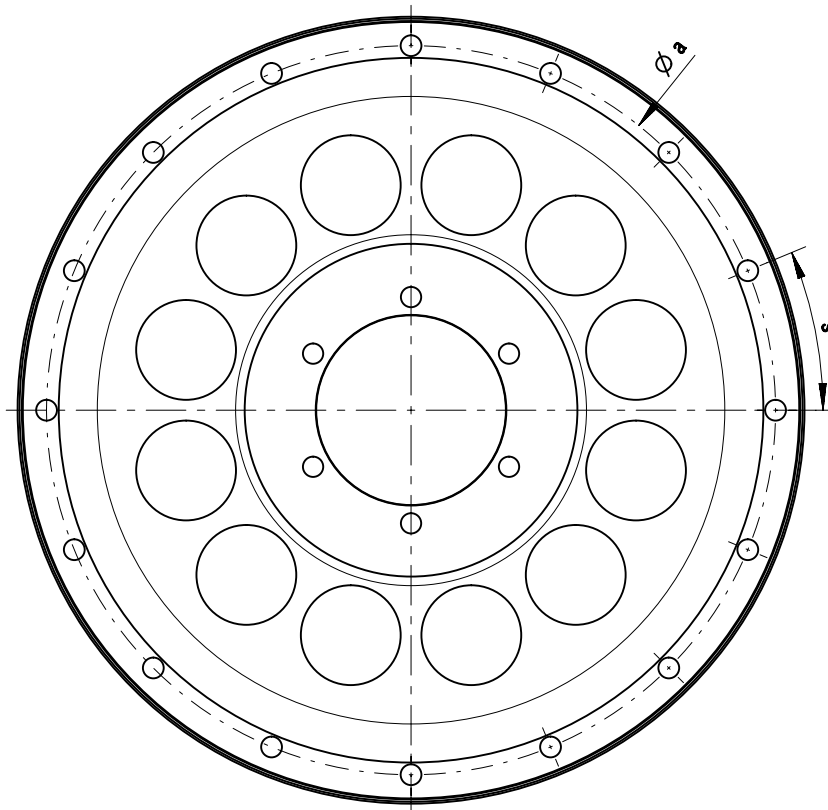

002413-R03

Type	D [mm]	L [mm]	a [mm]	e [mm]	h [mm]	k [mm]	s [°]	y [mm]	m [kg]	J [kgm ²]
A	466.7 g7	28.0	438.2	12.2	466.7 g7	12.0	12×30°	12.0	16.78	5.09E-01
B	466.7 h6	28.3 / 42.4	438.2	12.2	466.7 h6	12.0	16×22.5°	12.0	20.01	6.28E-01
C	392.0	40.4 / 55.4	345.0	10.5	345.0 h6	10.0	12×30°	8.6	14.68	3.52E-01
D	475.0 h6	28.3 / 42.4	450.0	10.5	475.0 h6	12.0	4×3×15°	12.0	20.65	6.62E-01
E	578.0	93.65	450.0	10.5	475.0 h7	10.0	4×3×15°	24.5	25.80	1.29E-01
F	475.0 h6	14.7	450.0	10.5	475.0 h6	12.7	4×3×15°	12.7	9.45	3.31E-01
G	473.0	13.7	438.2	12.5	466.7 h7	7.0	16×22.5°	14.7	10.35	3.63E-01
H	485.0 g7	12.0	438.2	12.2	485.0 g7	4.0	12×30°	12.0	18.26	5.96E-01
I	475.0 f7	28.0	450.0	11.0	475.0 f7	12.0	4×3×15°	12.0	16.74	5.22E-01
J	475.0 h7	28.3	450.0	10.5	475.0 h7	12.0	4×3×15°	12.0	17.81	5.57E-01

m - Mass

J - Inertia

Other dimensions available on request